

FIRST 2007 GUIDELINES, TIPS, & GOOD PRACTICES



TABLE OF CONTENTS

G	2007 FIRST Guidelines, Tips, & Good Practices	2
G.1	General	2
G.2	Conventions	2
G.3	SAFETY	2
G.3.1	General Shop Safety:	2
G.3.2	Robot-Specific Safety:	3
G.4	Kit of Parts	4
G.5	The Robot - Mechanical	6
G.5.1	General	6
G.5.2	Building the Chassis	7
G.5.3	DC Motors.....	7
G.5.4	The Drive Train	11
G.5.5	Miscellaneous	15
G.6	Robot Electrical.....	15
G.6.1	Building the Electrical System	16
G.6.2	12V Power System Overview	19
G.6.3	Motor Power Distribution	21
G.6.4	Sensors.....	24
G.6.5	Custom Circuitry	27
G.6.6	The Robot Controller	28
G.6.7	Operator Interface.....	31
G.7	Robot Pneumatics.....	34
G.7.1	Component Definitions	35
G.7.2	Pneumatic Electrical Distribution	36
G.7.3	Using Vacuum on the Robot.....	37
G.8	The Final Touch	38
G.8.1	Signal Light	38
G.8.2	The Flag Holder	39
G.8.3	One Last Look	39
H	WHERE TO BUY.....	40

G 2007 FIRST GUIDELINES, TIPS, & GOOD PRACTICES

G.1 GENERAL

The 2007 *FIRST* Guidelines, Tips, and Good Practices section is intended to provide fundamental information, useful thoughts, ideas, and basic direction as you start to design and build a robot. The information provided is consistent with good design practices and standards and, when followed and should yield excellent results for your project. The Guidelines section is intended to be used in conjunction with, but not to be relied on as a substitute for the FRC Rules or any FRC Supplier's specifications or technical documentation.

G.2 CONVENTIONS

Specific methods are used throughout this document to highlight Notes, Cautions, Warnings, key words or phrases to alert the reader to important information designed to help teams in constructing a robot complying with the Rules in a safe and workmanlike manner.

- **Notes**, **Cautions**, and **Warnings** appear in bordered boxes.
- Key words, Phrases, or References (important documents, drawings, etc) appear in bold italics.

Example: ***Always Wear Safety Glasses, 2007 Chassis Kit Manual***, etc.

- Operating keys, controls, buttons appear in bold capital letters.

Example: **OFF/ON** switch, **RESET** button, etc.

We have included references via [hypertext](#). Clicking on Blue Underlined Italic text or graphics will link you to another document containing specific detailed information related to the item or subject being discussed.

G.3 SAFETY

Regardless of whether you are an experienced veteran or “first-year rookie” team, a mentor, or a teacher participating in the *FIRST* Robotic Competition program, it is essential that safety be everyone's foremost concern at all times. *FIRST*, by presenting Industrial Safety awards, continues to celebrate teams that progress beyond the basic practice of safety fundamentals to those who have developed innovative ways to eliminate or protect against hazards,. The winning teams are those that consistently demonstrate excellence in practicing and promoting industrial safety throughout the competitions.

We are listing some important common sense safety fundamentals that need to be followed anytime, but particularly when involved in shop work, hanging around with the robots in the Pits at competitions, or within the vicinity of the competition playing field:

G.3.1 General Shop Safety:

- Obey all Safety Regulations as posted in the shop area.
- Always Wear Safety glasses. Eye injuries are the most common hazards in shop environments. Don't become victims; stay safe wearing your glasses.
- Wear proper clothing.

- Avoid wearing loose fitting clothing that could get caught up in shop machinery or by a sprocket & chain apparatus on the robot.
- Safety shoes should always be worn. Wearing sandals, open-toed shoes, or sneakers could be asking for trouble.
- Long hair should be restrained or covered by a cap to avoid any entanglement in machinery or mechanisms.
- Wearing good work gloves can save unnecessary wear and tear on your hands.
- Do not work alone in the shop. Use teamwork. In the event of an accident, immediate assistance should always be available.
- Untrained personnel should not use machinery.
- Keep hands and fingers away from machinery tools while in operation.
- Keep the work area neat and organized. Keep the floor clean of metal debris, oil, or greases.
- Use the proper tool for the job.
- Horseplay is not allowed!

G.3.2 Robot-Specific Safety:

G.3.2.1 Mechanical

- Use caution when working around the robot. Avoid and eliminate hazards posed by protruding objects and devices, spring-loaded actuators, sharp edges and corners. Where possible, de-burr all holes and sharp edges
- Confirm that all devices restraining mechanically stored energy are either safely secured or fully released before working on the robot.
- Use care whenever lifting and carrying a robot to avoid personal injury such as muscle strains and/or pinched fingers.
- When transporting the robot on carts, rest the robot on blocks and not on the wheels. Use bungee cords or tie downs to restrain the robot on the cart.

G.3.2.2 Electrical

- Shut the Power OFF before working on electrical circuits or exchanging components. Open the Main Circuit Breaker with the RESET button and/or unplug the battery.
- Remember to always verify the correct polarity when connecting devices. Some components may not be clearly marked. Always confirm the correct polarity from the manufacturer's manuals.
- Following electrical service work always inspect, test as necessary, and clear potential short circuits before applying power.
- Protect electrical circuits and wiring from accidental contact by persons and from contact with metallic foreign objects. Cover these areas with clear acrylic plastic panels where necessary.
- Routinely inspect batteries for cracked or damaged battery cases, or any evidence of electrolyte leakage, etc. Avoid contact with the battery chemicals and follow proper procedures for the handling and disposing of hazardous materials.

- Always use the recommended battery charger to prevent overcharging and potential damage to your battery. Old or defective batteries must be safely discarded as specified for the disposal of hazardous materials.

G.3.2.3 Pneumatic

- Respect stored pneumatic energy. Do not aim or direct high-pressure air at co-workers as a joke. Serious injury could be an unintentional result.
- Before servicing pneumatic components, confirm that the Main Vent valve is fully open. Inspect all pressure gauges to verify that NO pressure is present.
- Stay clear of any cylinders and mechanical attachments when the air system is charged; particularly keep clear when setting a cylinder in motion.

G.4 KIT OF PARTS

The **FIRST 2007 Kit of Parts - Section 10** (of the FIRST Robotics Competition manual) is the source for useful information concerning the kit contents for 2007 and “Who to Contact” for obtaining any replacements for any missing items from the kit. In addition, Section 10 provides contact information and the process to purchase extra kit materials and replacement part. A description of the FRC loan policy, procedure, and requirements for borrowing Control System components at competitions whenever necessary is included.

In this document we call attention to various parts and particularly to some of the new items found in the kit. Collectively, they can add some useful features and capability to your robot for this year’s competition. At the end of this document, teams can find a “Where to Buy” list to aid in shopping for additional KOP items.

The table below provides a listing of the 2007 Resources and Suppliers providing materials and support for FIRST Robotics teams. Teams should plan to visit these websites to discover the broad range of products, technology, science and services available from these companies. Perhaps, even scope out potential future career opportunities.

For specific product or kit parts information, we always encourage teams to explore the FIRST web site at http://www.usfirst.org/robotics/doc_updt.htm, and the Innovation First web site <http://www.innovationfirst.com> to download essential parts documents and specifications of interest. Many of these documents are available to you from these locations.

Table of Resources & References

Resource/Supplier	Kit Product Type	Web Site
American ANKO Co.	Joysticks	http://avb.store.com/
Allegro Microsystems	Gear Tooth Sensors	http://www.allegromicro.com/
Analog Devices	Dual Axis Accelerometer, Yaw Rate Gyro	http://analog.com/
Anderson Power Products	Quick Disconnect plug, P/N 6331G1	http://andersonpower.com/
AndyMark, Inc.	6" wheels, Sprocket 24-tooth, Battery safety plug	http://www.andymark.biz
Autodesk	Inventor, 3D Studio Max	http://www.autodesk.com

	software	
BaneBots	Motor, gearbox, 12:1 Planetary transmission,	http://www.banebots.com/
Bimba Manufacturing	Special order pneumatic cylinders	http://www.bimba.com/
BishopWisecarver	DualVEE wheels, bushings, rails	Email to sales@bwc.com
Bosch-Rexroth	Pneumatic Valves	http://www.boschrexroth.com/
CCL Industrial Motor, LTD	CIM motors	http://www.cimmotor.com/
Clippard Instrument Laboratory, Inc	Volume Tank	http://www.clippard.com
Delphi Connection Systems	Wire & cable	http://www.delphi.com/
Delphi Electronics & Safety	Sensor panel components	http://www.delphi.com/
EPM-Pabst	12V Muffin Fans	http://www.ebmpapst.us/
FCI Burndy	Tie wraps, SCRULUGS	http://www.burndy.com/
Festo	Single solenoid valves	http://www.festo.com
Fisher-Price	Motors & Motor/Gearbox Assy	http://www.fisher-price.com/
Flexcon Corporation	Totes	http://www.flexconcontainer.com.
Fluid Power Education Foundation	Pneumatic System education	http://www.fpef.org
Freelin Wade	Tubing products	http://www.freelinwade.com/
Globe Motors	Globe motor	http://www.globemotors.com/
HPE Automation	Teflon Tape	http://www.hepco.com
IDG	Sprockets, Chain & hardware	http://www.idglink.com
IGUS	Plastic bearings & guides	http://www.igus.com/
Innovation First, Inc.	Robot Control system, Kitbot, <i>FIRST</i> Store	http://www.innovationfirst.com/
Intelitek	Easy C software	http://www.intelitek.com
Kent Elastomer	Latex tubing	http://www.kentelastomer.com/
Kerk Motion Products	Lead screw & nut	http://www.kerkmotion.com
Keyang	Window motors	http://www.keyang.co.kr
Lord Corporation	Vibration isolaters	http://www.lordmpd.com
Mabuchi Motor Co.	Mabuchi motor	http://www.mabuchimotor.co.jp/
Microchip Technology	CBOT Compiler	http://www.microchip.com
MK Battery	12V Battery	http://www.mkbattery.com/
MBB Bearings	Bearings	Email to sales@mmbbearings.com
Monnier Corp.	Regulator & bracket	http://www.monnier.com/

Nason Company	Pressure switch	http://www.nasonptc.com/
National Instruments	Labview software,	http://www.ni.com/
Norgren	Regulator, gauge, relief valve	http://www.norgren.com/
Oznum	Cold cathode lights	http://www.oznum.com/
Piab	Vacuum cup, pump	http:// www.piab.com
Plastic Supply	HDPE Target lens	http://www.plasticsupply.com/
Rockwell Automation	Relays, Signal devices, DIN terminal equip.	http://www.rockwellautomation.com/
Sager Electronics	Micro Switches	http://www.sager.com
Sangin International	Swim Rings, Red/Blue	To be announced via email blast
Sanyo	7.2V Nicad battery & charger	http://www.sanyo.com
Schumacher	6 Amp Battery Charger	http://www.schumacher.com/
SMC Pneumatics, Inc.	Pneumatic fittings	http://www.smcusa.com
Terminal Supply Company	Fuse panels & terminals	http://www.terminalsupplyco.com
Thomas Industries	Air compressor	http://www.thomasind.com/
Tyco	Terminal lugs	http:// www.tycoelectronics.com
Underwriters Laboratories	DVD, Safety Training	
US Patent & Trademark Office	DVD, (title)	
Wika Instruments	Pressure gauges	http://www.wika.com/

** New Suppliers

G.5 THE ROBOT - MECHANICAL

G.5.1 General

This year it is most likely that teams will continue to design and build robots in a variety of forms to perform the games strategic functions. Many robots will be speedy and highly maneuverable. Other designs might focus on strength and control, or altering configuration to gain advantage. Most designs will be very capable of withstanding vigorous interaction with other robots. The end product for each team customarily will be the result of brainstorming and building to a unique game strategy and a plan beneficial to an alliance. Along the way, here are a few important design concepts to keep in mind.

- **Remember thy Robot Weight Limit-** All of the elements of the robot such as the drive system, frame, electrical system, pneumatics, and all other mechanisms share a portion of the robot's overall total weight. In particular, *this year all teams need to verify the robot weight restrictions that are applicable to the robot design as stated in Section 8 of the FRC Manual.* The maximum weight allowance for certain designs is less than 120 pounds without the battery, ½ of the Anderson Power connector, and the bumpers mounted on the robot.

In every case, the best strategy is to set up a "weight" budget plan for each element or segment of your robot (such as 25% drive train, 15% electrical, 15% pneumatic, etc). Then stay within the weight budget throughout the build cycle. At the end of the project you just might have some

allowance to add a bit more weight to enhance a robot system or two as needed and avoid wasting time performing a “panicky” weight reduction process at your first Regional inspection.

- **Keep it Simple** – The more complicated the robot design, the more likely something will go wrong. Focus on strengthening the weakest points of your design for best reliability.
- **Build it Right** – Consider certain basic principles such as keeping the mass weight of the robot as low as possible for best maneuverability and stability. Plan to locate all delicate devices, circuitry, and sensors inboard of the framework and under cover for best protection.
- **Change is good** – A sign of progress as you go along building the robot is that you will find modifications and adjustments are necessary. It might mean relocating transmissions, moving electrical components, or reinforcing structures. It may include adding materials to repair or enhance a mechanism. Always keep in mind to control your weight budget and implement any changes accordingly.
- **It’s Gotta Go in the Crate** – Remember that at the end of the project the robot has to fit inside a shipping crate having a maximum “external” dimension of a 4-foot x 4-foot footprint and a height limit of 70 inches. The 70-inch height limit includes the 4-inch base supports required on the bottom of the crate as well as the thickness and height of any framing lumber on the top edges of the crate.

So, plan ahead... The (probable) headroom space inside the crate will limit the shipping height of the robot to roughly about 5’ 2”. The maximum weight of the fully loaded crate can be up to 400 pounds before “excess shipping tariffs” kick in. See the **Transportation, Section 4** of the FRC manual for complete crate specifications and shipping requirements.

G.5.2 Building the Chassis

As always, the robot’s chassis is constrained by a maximum size, or volume that the robot can have at the start of a match. The area of the footprint must be less than 28 inches by 38 inches.

Historically, teams would spec out the necessary metal or wood and begin by constructing a suitable platform. However, the 2007 Kit of Parts includes the *KitBot* box. The Kitbot materials provide a lightweight, rugged, and adaptable solution for constructing a serviceable robot frame quickly and efficiently.

There are a number of ways that Kitbot components can be configured to form a chassis. The absolute design decision is defined by your team’s game strategy and the functions the robot will need to perform. Once the basic chassis style is determined and has been assembled, the motor and transmission assemblies can be mounted and the drive wheels added.

The **2007 Chassis Kit Manual** found on the Innovation First web site <http://www.innovationfirst.com/> provides the important step-by-step instructions to assemble the most common version of the Chassis kit and for mounting the drive train. One example is shown here.

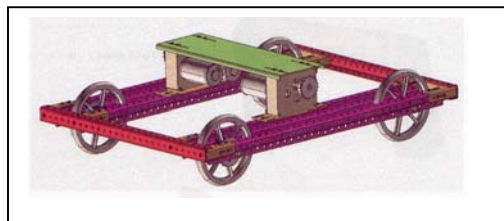

Some robot styles and strategies are not allowed again this year in the competitions. Wedge designs are still prohibited; dangerous or hazardous protuberances are not allowed, sharp corners and edges are not permitted, and strict bumper contact zones will be enforced. So, plan ahead, be familiar with the rules, and build accordingly.

G.5.3 DC Motors

Selecting an appropriate motor to perform a specific function such as turning a wheel, lifting an arm, or squeezing claws is an important part of the design process. Motors that may be used in

the 2007 FRC competition are those supplied in the 2007 KOP or as permitted by the 2007 FRC Rules found in Section 8 of the FRC manual. The 2007 kit motors are listed in the table below.

Although some choices are obvious, before you begin to make motor selections, you should have determined a few pieces of information. First, know what type of robot you intend to build. Must it be fast and maneuverable, or methodical and precise? Factors such as moments of inertia, friction characteristics of the load, and power needs are relevant. Perusing the different motor properties such as RPM, torque, speed, power, and weight will help you to focus on those most important factors to facilitate your design

Each motor shown in the table has a unique set of speed/torque characteristics that can be adapted to perform work by the robot. Some are quite powerful and draw high currents when loaded to their limits. Others have very high-speed capability. Some include gearboxes that define their gear reduction, output shaft speed, and torque output. The table provides the peak power rating, torque and current at “stall”, and the “no load” speed and current for the kit motors typically based on the voltage input of 12Vdc (or as shown in the “Notes” column).

Motor Type	Description	Notes	Peak Power	Gear Ratio	Operation At Stall		Operation No Load	
					Torque	Current (Amps)	Speed (RPM)	Current (Amps)
		Data @						
BaneBots Mabuchi	Motor, RS-540	12Vdc			230 mNm	37	17500	.95
BaneBots	36mm Gearmotor/w 2-stage	12Vdc		16:1	Multiply above times 16.	37	1090	.95
CIM FR801-001	Keyed output shaft, ccw	12Vdc	337 W		343.4oz-in	133	5310	2.7
Fisher-Price FP801-005	16 Tooth Pulley	12V dc	270 W		570 oz-in	96	2700	1
Fisher-Price	Motor Portion of 9012	12Vdc	387.5W		417.7mNm	63.5	15636	1.06
Fisher-Price 9012	9012 motor w/gearbox, Power Wheels	See Above	See above, subtract losses	124: 1	Multiply above times 124.	63.5	125	1.06
Globe 409A587	4WD/2WD transfer mtr.	10Vdc	55 W	117: 1	150 In-lb	21.6	81 +/-7	0.82max
Keyang 16627960	Window motor, RH	13Vdc			12 Nm	20	85	2
Keyang-16627961	Window motor, LH	13Vdc			12 Nm	20	85	2
Nippon-Denso 3030	Window Lift, RH	12Vdc	22W		10.6 N-m	18.6	84	1.8
Nippon-Denso 3040	Window Lift LH	12Vdc	22 W		10.6 N-m	21	84	1.8
Mabuchi RS-545SH-2485	W/spur gear CCW rotation	12Vdc	16.8W		60.8mNm	5.2	4700	0.22

The Kit motor specifications normally provide torque/speed characteristics in tabular and/or graphical forms. The torque/speed curves for most motors are depicted as linear from max to min ranges and these curves can provide a good deal of information about the motor.

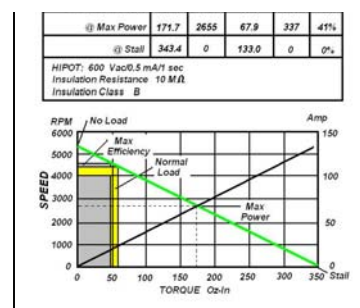

In the graphic shown here, a torque curve (black line) of the CIM motor rises from “0” torque along the “X” axis to about 343.4 Oz-in torque at “stall”. The motor “speed” curve (green line) on the “Y” axis reaches a maximum RPM of 5310 at “0” torque (no load) with the motor current about 2.7 Amps. However, torque and speed are inversely proportional. As torque (load) increases, the speed drops toward “0” or toward the “stall” condition while the motor current rises and will peak around 133 amps at the “stall” condition.

The point where the two curves intersect is the measure of “Maximum power”; where speed, peak power, and torque for this motor are optimized. For any motor this point becomes the truest measure of a motors power, taking into account the torque and speed character of the motor.

The yellow box indicates a suggested normal load range (as determined by the manufacturer) for this motor at a torque output up to 64 oz-inches, a current of about 27 amps, and a speed up to 4350 RPM. Teams will ultimately determine their own normal operating range, based on their robot requirements. Perhaps altering the gear ratio to trade-off higher power consumption, with a little less speed to gain more torque will be very important in the design.

As you can see by the graphic, at the Max Power point, a typical CIM motor would operate at a speed around 2800 to 3000 RPM at its output shaft. Obviously this is too fast to connect directly to the wheels. Besides, the available torque at those speeds is pretty small. Typically some gear reduction (around 12:1) with a transmission and sprockets will bring speed down to around 230 to 250 RPM and increase available torque. The benefits are gaining starting power, getting the top speed down to something that can be controlled, and increasing the pushing power and maneuverability of the robot.

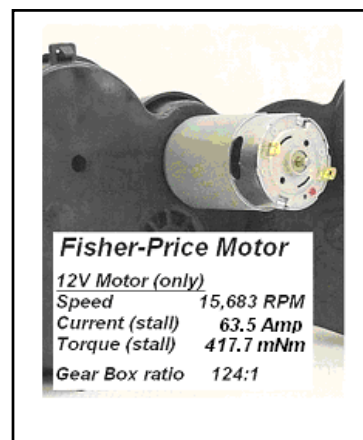

The torque/speed data presented here is based on a single voltage level (12V). In actual operation the motor speed/torque will shift toward the origin as the voltage applied to a motor is reduced because of joystick setting or by the decreasing battery voltage. A low battery produces lower current, speed and torque. Conversely, higher voltage yields higher torque and speed delivering higher current and allows more heating of the motors.

Most of the motors supplied in the Kit were not originally designed to drive robots. For example, the motor shafts on the Globe and Mabuchi motors are designed to provide axial torque only, and drive secondary shafts or mechanisms. They do not like significant transverse or side loads imposed on their motor shafts. When using these motors, always take care to securely fasten the motors to a proper gearbox or couple the output shafts via flexible couplings to the business side of a drive train when used for motive power (as suggested in this graphic).

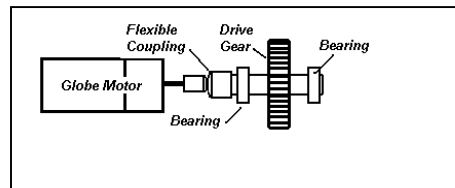

Selecting appropriate ratios for gears, sprockets, chains, etc. to perform within a motor’s power band is the goal. Poor motor performance or premature failure may occur if the transmission ratios employed are not properly chosen to allow motors to operate within their preferred or “normal” torque/speed/current ranges. Using kit supplied gearboxes and sprockets will make these choices easier for you. In some cases, gear change kits, adapters, and/or sprockets may help you fine-tune a motor to better suite your application.

G.5.3.1 Motor Bias

When looking at the Motor table, teams should be aware that certain motors have a built-in bias toward rotating in a preferred direction. This bias, a result of brush timing, will cause the motor to produce slightly more torque and turn a bit faster. In the reverse direction of rotation, the same motor will run a bit slower while producing less torque. For example, a pair of CIM motors might exhibit timing bias symptoms as follows: When the robot is steered forward one

motor rotates in the clockwise direction while the companion CIM motor is rotating counter-clockwise. With pronounced bias, any speed difference between the motors will cause the robot to drive off the intended straight track to one side. Generally CIM motors are fairly well balanced, but should you encounter this symptom you may need to try a different motor pair to achieve a more balanced result.

So, be cautious and consider most torque/speed curves as valid only for the primary direction of rotation. If balanced performance will be critical to your design, torque/speed measurements of motors should be checked in both directions.

Note in the table above that CIM motors are very capable of drawing in excess of 100 Amps at stall. Operating these motors near the Max power point for more than a few seconds will likely trip the auto-resetting 40 Amp circuit breaker and result in losing drive control of the robot until the circuit breaker cools sufficiently. The breaker will eventually reset, and the motor will resume operation. In competition, its far better to limit or avoid this situation and in your design select gear ratios that will keep the motor current operating within the safe range of the current protection offered by the circuit breakers.



G.5.3.2 Special Notes on Motors

CIM motors - The 2007 Kit of Parts again provides two FR801-001 CIM Motors. The kit also includes 1 - FP801-005 Mini-bike motor. The torque/speed data for the motors appear in the Motor table at the start of this section. The Parts kit also includes a pair of NEW 12:1 56mm planetary gearboxes supplied by BaneBots. These assemblies readily accept mounting of FR801-001 CIM motors supplied in the kit. Section G.5.4.1 describes a procedure to fit the motor onto the gearbox.

G.5.3.3 Nippon Denso motors

The Kit includes One Nippon- Denso Window motor. Either a left hand version OR a right hand version of the motor is supplied. These motor/gearbox assemblies have an automotive quick-connect electrical connection, which is a Packard type (P/N 12129487). The Packard mating connector part number is 12129486. This item is not provided in the kit.



While having a genuine mating electrical connector is ideal, an alternate connection method for this motor would be to use a pair of 14-16 gauge female insulated Slip-on (Quick Disconnect) terminals such as Terminal Supply part BB-8135 or Stakon's RB14-110F terminals. These terminals fit posts 110 x .032 in. and will make a firm and reliable connection for the motor.

In the KOP Red tote you will also find a 9-toothed plastic coupler supplied by DEKA to mate the Nippon Denso motor output gear either to a 5/8-inch keyed shaft, or by the flange coupling, to a plate to drive a mechanism.

G.5.3.4 Keyang window motors

Both left hand and right hand versions of the Keyang Window motors are supplied in the KOP. These motor/gearbox assemblies have an automotive quick-connect 2-piece electrical connector supplied in the Terminal bag.

The kit includes (2 ea.) couplings to mate the output gears of the Keyang window motors to drive various mechanisms. Check your couplers! The window motor output gear on the



Keyang motor is also 9-toothed, but it is not identical with the Nippon Denso motor.

G.5.4 The Drive Train

The Mechanical Drive Train consists of those components that connect the drive motors to the wheels or tracks of the robot.

Some general advice if you plan to build up an alternate robot drive system from scratch is offered below:

- If designing an axle-based drive train, assure that the weight of the robot is fully supported by the axles and shafts of the transmission or gearbox, and not by the drive shaft of a motor. Use bearings and bushings on the axles and shafts to provide proper support and minimize friction. Remember, the greater the robot weight, the more internal friction the drive train components will experience. Align mechanical power transmission components accurately.
- If you couple a motor shaft to another shaft assure that the coupled shaft is supported with bearings at two points as shown previously. Use flexible couplings to connect the motor shaft to the shaft.
- Incorporate sufficient gear reduction in your drive train to provide ample drive torque for the desired robot speed.

G.5.4.1 12:1 56mm Planetary Gearbox

The KOP contains a pair of 12:1 56mm planetary gearboxes from BaneBots to provide drive interface capability for the robot. These transmissions are a specific match for the CIM FR801-001 motors provided in the KOP. Using these transmissions, the gears, sprockets, chain, couplings, and connections in the Kit provide not only convenience, but take advantage of one proven solution for speed reduction and power transmission between the CIM motors and the robot drive load.

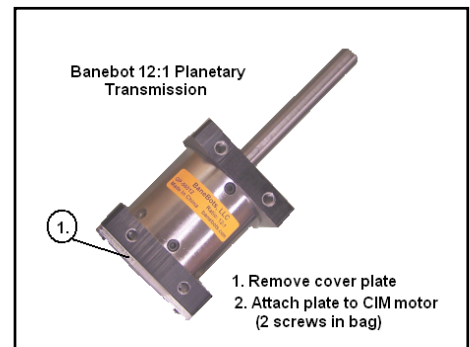

The gearbox kit includes the gearbox, 1ea. Bushing, 1ea. Pinion gear, 1ea. 2mm-key, and 2ea. screws. Use the following steps to assemble the motor/gearbox:

- 1) Use a 2.5mm Allen key to remove the four screws holding the back plate attached to the rear flange of the gearbox. Remove and discard the protective paper and lay the gearbox aside.
- 2) Attach the back plate onto a CIM motor using the two screws supplied in the gearbox kit. Tighten securely.
- 3) Insert the 2mm-key fully into the keyway on the CIM motor shaft. Align the key slot of the bushing and slide the bushing onto the shaft. Line up the pinion key slot with the key and slide the pinion gear onto the motor shaft.
- 4) Install the CIM motor shaft and pinion assembly fully into the 56mm gearbox. Secure the gearbox flange plate to the motor plate using the four screws removed in step one.

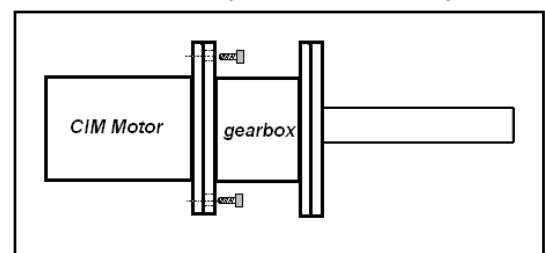
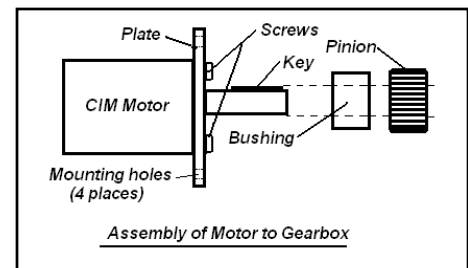

A useful drive train accessory offered by BaneBots may be a 2-CIM Motor Adapter. This kit combines and couples the output of a pair of CIM Motors to operate a single 12:1 56mm planetary gearbox. The adapter will permit approximately a 2X torque improvement at a cost of 2X power consumption. Visit <http://www.banebots.com/FIRST> for details on accessories

G.5.4.2 Assembling the Wheels

The *FIRST* KitBot chassis typically supports a fixed-axle system where the driven sprocket is mounted directly to the wheel hub and not onto an axle. Four 6-inch wheels are provided in the KOP supplied by AndyMark. A starting point will be to install the bearings into each wheel. Each wheel requires two bearings.



G.5.4.3 Bearing Insertion

Inserting a pair of bearings into each side of the wheel hub is normally a simple operation, particularly if an Arbor Press is available in the shop. The wheel hub has a slight recess at the opening of the bearing cup and this recess helps to set the bearing in a true orientation for insertion.

- Center the wheel and bearing under the press face. Apply moderate light pressure on bearing face to start driving the bearing down into its recessed position.
- Check that the press surface applies equal force across the entire bearing face and not just on the inner race of the bearing. Also check that the bearing is uniformly being driven into the hub. If the bearing is not properly aligned, the bearing and/or the wheel hub could be damaged.

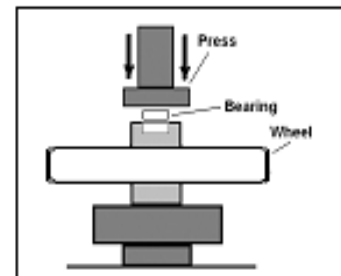

The bearings could also be more crudely inserted by using a soft-headed hammer or rubber mallet. Lay an intermediate flat surface such as a small metal plate over the bearing and tamp on the plate to seat the bearing. After both bearings have been installed in all four wheels, the 24-toothed drive sprockets can be screwed or bolted onto the hub assembly of the drive wheels using appropriate hardware.

Note that these R8 bearings have open races. The bearings are lightly oiled. Once installed, the bearings should be coated "lightly" with bearing grease. Teams are also advised to periodically check the wheel bearings, clean and re-lube as necessary.

G.5.4.4 Adding Sprockets

A pair of 24-tooth sprockets is provided in the Drive Train bag to drive a basic 2WD system. A 4WD system requires that each wheel be driven and all wheels must be fitted with a 24-tooth drive sprocket. In this case, two more sprockets must be ordered.

Each wheel hub has 6 holes that could be drilled through using a 3/16" bit. Then insert 6 ea. #10-32 x 1.75" Round or Button head SS machine screws through the sprocket and mating hub holes. Or, the hub holes could be tapped with a 10-32 tap to accept # 10-

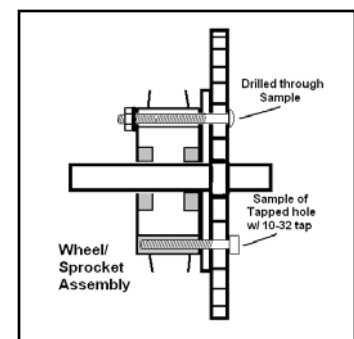

32 x 1.5" (ea.) Socket Cap screws. The figure shows examples of "drilled through" and "tapped" hardware.

Finish by installing the lock washer and nut hardware and tightening onto the screws. Once the sprockets are in place, the wheels will now be ready for mounting onto the chassis frame.

G.5.4.5 Wheel Placement

When using the Chassis kit typical frame design, a 5" long 1/2" Hex Head Cap bolt could serve as a cost-effective and satisfactory axle. The holes in the chassis rail must be enlarged from 3/8" to 1/2" to accommodate the larger bolt required.

Alternately, a 5" long 3/8" Hex Head Cap bolt may also serve as a cost-effective and satisfactory axle. Additional spacers, sleeves, and washers should be used to take up the free space between the bolt and

wheel bearings and to keep the wheel in a semi-fixed position on the axle. The wheels should wind up being more or less centered in the wheel channel. The exact placement is determined by the position of the drive sprocket on the transmission output shaft.

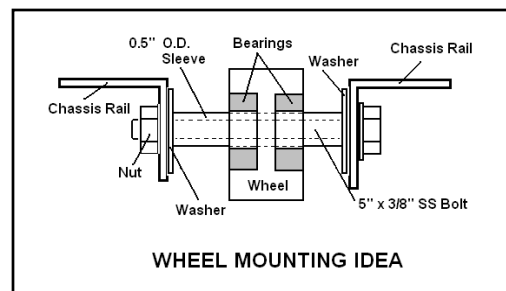

Depending on the robot design, 2WD may call for the driven wheels to be mounted at the rear of the chassis or mounted forward. The left-side wheel arrangement opposes the right side in that the sprockets will face outward on the rear wheels. The wheels can be positioned forward or backward from the locations shown in the drawing and that placement will impact the maneuvering and stability of the robot platform. There is adjustment available in the wheel channel to accommodate changes gleaned from driving tests & evaluation.

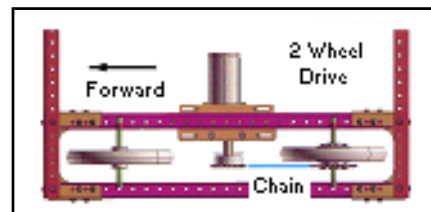

In a 4WD system each wheel is equipped with a sprocket. However, the wheels in each channel need be installed so the inner wheel sprocket will mate up with the inner drive sprocket on the transmission shaft and the outer sprocket can mate up with its outer sprocket. For 4WD, the left-side wheel channel arrangement mirrors the right side. For example, in the picture the right forward socket is facing the outside. On the left side of this frame the forward sprocket will face the inside. The drive wheel sprockets can then be connected to the individual transmission sprockets via chain when the transmissions are mounted.

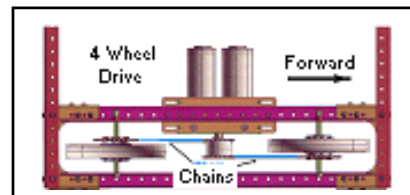

G.5.4.6 Mounting the Chain

No doubt you have discovered that the KOP includes a 10-foot length of ANSI #35 chain and a pair of master links. #35 chain is selected because it can handle abuse appropriate for robotic needs without being too heavy. Chore #1 will be to determine the length of chain you will need between sprockets. Chore #2 is to break the existing chain at the necessary length with a chain breaker tool. Finally, chore #3 will be to join the chain back together with a master link. The number of chains you will need depends on whether the robot will be a 2WD, 4WD, or perhaps even a 6WD robot.

Now that you have the frame, with a pair of transmissions mounted on the frame and a set of wheels mounted as shown in the figures above, you will need to size, break, and join two clean

ends of the chain with a master link. When you size the chain, select a particular link & pin that will produce a “clean link” (end with an open internal hole). The length should result in the chain being slightly longer. That’s better than ending up with a chain that’s too short.

The tool you’ll need is a “Chain Breaker”. This tool is designed to slip over and grip the links on the chain by squeezing the handles as shown.

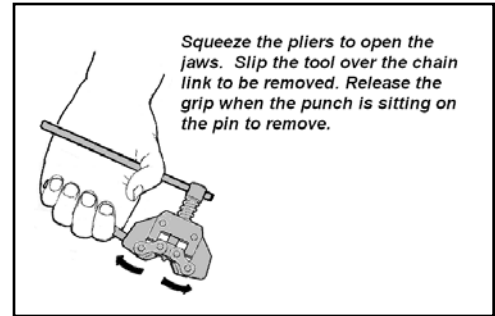

The tool “punch tip” should be positioned directly over the pin to be removed. When the punch is sitting squarely on the pin, turn the upper handle “cw” to start driving the pin down through the link plate. When the pin is about even with the plate surface, move the tool to the second pin and drive it down into the plate about half way. Finish by driving pin 1 through the link plate and then drive pin 2 through the link plate.

Now that the chain is broken to the correct length all that remains is to rejoin the chain on the sprockets with a master link. The master link (in the drive train bag) is the reusable link that uses a side plate and spring clip to hold the chain together.

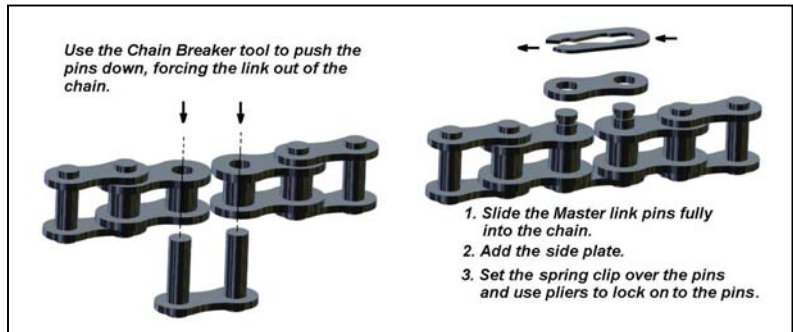

- 1) Wrap the chain onto the sprockets such that the clean links are supported on the sprocket.
- 2) Slide the master link fully through both pinholes.
- 3) Add the side plate over the master link pins.
- 4) Place the spring clip (as shown) over the pins with open end of the clip touching the second pin. With pliers, squeeze the end of the clip using the pin as a lever and guide the open end of the clip around the second pin.

Here are a couple of points to check as you are connecting chains:

- **Alignment**: Be sure that the wheel sprockets and gearbox sprockets are properly aligned with each other. Verify the sprockets are in the same plane with the chain attached. The chain must not be cocked at any angle, but will always leave the sprocket gearing in a straight path toward the mating sprocket as the wheel is rotated in either direction.”
- **Chain Tension**: Check the chain tension. If the chain is too loose or sloppy, it could result in poor response to direction changing and in the worst case, could start jumping teeth on the sprocket resulting in lost drive. The rule of thumb for slack is about 3% of run length (distance between sprocket centers). Typically +/- 0.5”.

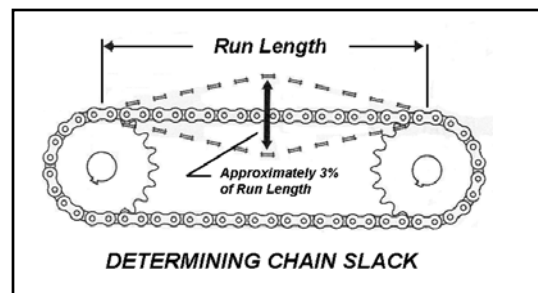

- **“Stretch”**: New chains will “stretch” after installation and it is most likely that some slack will need to be eventually removed. However, if the chain is set too tight at this point of

assembly, keep in mind that when the full weight of the robot structure is applied, the transmission components and the drive train will likely be subjected to extreme friction with a serious reduction in drive efficiency. The “ ideal” chain tension initially is that point where the chain will not slip.

G.5.5 Miscellaneous

G.5.5.1 DIN Mounting

In the Kit of Parts you will find a pair of rails, sometimes known as DIN Rails. They are steel hat-shaped rails 35 mm wide and supplied to *FIRST* teams 18” in length.

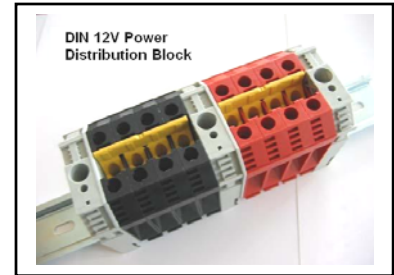

DIN” is an acronym from an old German national standard (Deutsches Institut für Normung). You often hear DIN referenced to various electronic components, particularly for audio connectors.

The DIN rails are primarily intended to mount the red and black terminal blocks found in the Power Distribution Block bag and the solid-state relay module for the signal light. They could be used to mount and support various solenoids and the vacuum pump. The Power distribution block is used and featured in the 12 V Power System section of this chapter.

Typically the DIN rail is cut to the length required for the termination devices. In this case the block assembly shown below is 5 inches wide and the DIN rail has been cut to about 7 inches length to expose the mounting slots on each side of the block assembly.

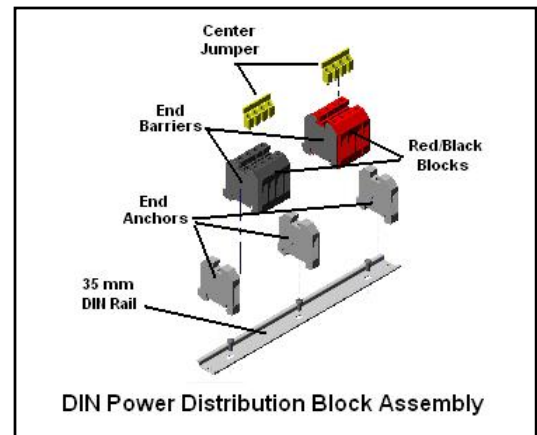

In the bag you should find 4 Red and 4 Black Feed-thru Connector blocks, 3 ea. - End anchor blocks, 2 ea. - Center jumpers, and 2 ea. - End barriers. These parts are illustrated in the diagram above and shown in the typical order in which, and where they are assembled (each piece is slid onto on the DIN rail in sequence. The end anchors lock the assemblies in place on the rail. The bank of four black blocks are linked together with a center jumper. The second center jumper links the red blocks. Use an end barrier to cover the “open” end of each connection block as indicated in the assembly figure.

Tighten all the anchoring and linking screws securely. The *2007 Power Distribution wiring diagram*, and the discussions that follow will guide you in making proper power connections for your robot.

G.6 ROBOT ELECTRICAL

The Electrical System is the primary source of energy for the robot. The system includes the 12V battery, the electrical devices and the network of wires that distribute the electrical energy to the motors, to the pneumatic actuators, and to the Robot Controller and sensors. The block drawing illustrates the basic electrical energy supply relationship

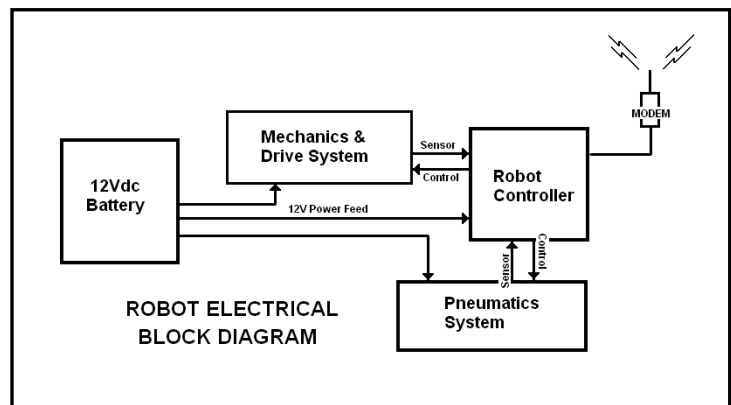

between the Main Power system, the Mechanics & Drive systems, Pneumatics system, and the Robot Controller.

One can see that getting full electrical energy from the battery supplied to each system is important to the robots total performance. Thus, it seems appropriate to begin this electrical system discussion by first focusing on the electrical network and the means to provide the necessary power to do the work.

G.6.1 Building the Electrical System

G.6.1.1 Wire & Wire Size

For those not familiar with electrical standards, all wires are classified by the American Wire Gauge system, and are assigned “gauge” numbers according to the wire’s cross-sectional area. The table shows standards for the AWG gauge number including: the diameter in inches and millimeters, the wire resistance per 1000 feet, and a maximum rated current for the wire gauge at 12Vdc input.

Note the higher the AWG number, the smaller the wire size. For example, a #20 AWG wire has a diameter of 0.0369 inches. A #12 AWG wire has a diameter of 0.0933 inches.

**AWG STRANDED WIRE
Resistance & Voltage Drop Table**

Size		Resistance ohm/1000'	6 feet Resistance (Ohms)	Voltage Drop (Volts)	Maximum Current Capacity
AWG	Diameter inch				
20	0.0369	10.360	0.0622	6.22	5 A
18	0.0465	6.520	0.0391	3.91	7 A
16	0.0587	4.080	0.0245	2.45	12 A
14	0.0740	2.580	0.0155	1.55	20 A
12	0.0933	1.620	0.0097	0.97	30 A
10	0.1177	1.020	0.0061	0.61	50 A
8	0.1484	0.640	0.0038	0.38	80 A
6	0.1871	0.402	0.0024	0.24	125 A
4	0.2360	0.253	0.0015	0.15	200 A

Calculation shown for 6 feet of wire @ 100 Amps @ 12Vdc
Max Current rating based on allowable 2.5% voltage drop

Two additional columns show the wire resistance for a 6-foot length of the cable and the voltage drop in that section of cable when a 100A current flow is applied through the wire. The maximum current rating is based on a 2.5% voltage drop.

FIRST Robot Rules specify the minimum allowed wires AWG sizes that may be used to supply the robot’s electrical loads. Remembering that choosing the wire size (AWG) can be important toward delivery of full power to a load while protecting the wiring integrity, teams may opt to use somewhat larger gauge wiring (smaller AWG number) to compensate.

G.6.1.2 Polarity and Current Paths

In addition to being electrically isolated from each other, all positive and negative wiring **must** be isolated from the robot’s chassis. Teams must ensure that no electrical devices or custom circuitry on their robot are electrically common with the chassis (no “grounded” housings). **The negative terminal of the battery must not be connected to the robot chassis.** Teams should use the *2007 Robot Power Distribution diagram* as a guide when wiring their robot.

G.6.1.3 Cable Routing & Harnessing

FIRST recommends all teams take the time to follow good cable routing & harnessing practices and that all wiring be laid out in a logical, orderly manner between circuit devices.

- Whenever possible, harnesses should be sorted and separated into “power” and “PWM/sensor” cable groups. Ideally they should be run in different pathways to their destinations. Minimizing interference between wires could become an important factor to the robot’s reliable performance. In addition, “grouping” can be a useful aid in troubleshooting and servicing

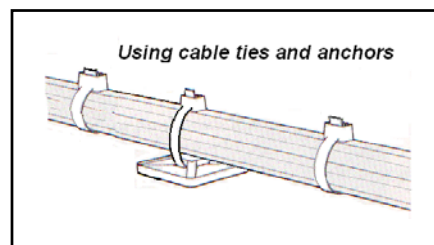

the robot. Choose a safe and protected pathway inboard the main robot frame for the harness to ensure the robustness and reliability of the electrical system.

- Wires leaving devices should be grouped and bound together with plastic ties to form wire harnesses. Binding the wire bundles together using plastic tubing or quick ties and chassis anchors provides firm support for wires in rugged environments.
- Wires and groups of wires, passing through chassis holes or around cutouts with sharp edges, need to be protected, usually by a plastic sleeve, plastic tubing, plastic helical wire wrap, or by rubber grommets against chaffing.

G.6.1.4 Wire Terminations

As you build the robot, keep in mind that any connected wire terminal or plug may need to be disconnected for service on occasion. It's normally a good idea to provide a small amount of slack in the wire to permit detachment from terminals. However, leaving excess slack should be avoided. Not only can it be messy, but loose wires might get pinched, grabbed, and torn away by intruding robots at the most inconvenient times. Use good judgment both in routing, securing harnesses, and terminating wiring.

G.6.1.5 Terminations

One key towards getting full power delivered to load circuits in the robot's construction is in fabricating good terminal connections. This may sound simple, but to maintain electrical integrity, tensile strength and insulation properties, sound-crimping techniques must be used.

The drawing gives an example of a typical robot electrical circuit. The "R" components represent the resistances added to the circuit from each terminal connection. Ideally, these would be always be "0" ohms. However, one bad crimp or poor solder job could insert lots of "ohms" into a circuit, equaling one big voltage drop, and plenty of lost power.

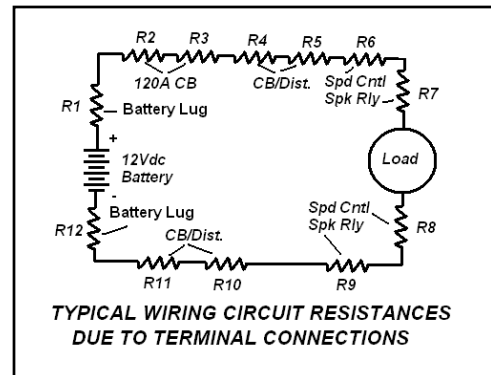

A good crimp relies on the preparation of the wire, the terminal type, and the quality and use of the crimping tool. If any of these items are out of specification, an unacceptable crimp may result. The general rule is to strip the outer insulation from the wire using a wire stripper tool with cutting slots matching the wire gauge size. The insulation should be stripped (approximately 1/4") so that, when fully seated in the terminal lug, the ends of the wire strands just protrude through the barrel.

Slide the terminal lug over the wire strands so that all strands are fully into the terminal sleeve and the wire insulation is under the insulating sleeve of the lug and just butting up to the inside sleeve inside the terminal barrel. The wire insulation must be fully seated inside the lug insulation sleeve for proper support. You should now see the tips of the copper strands just protruding through the barrel.

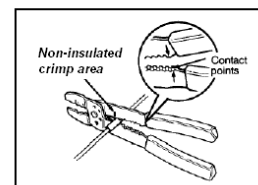
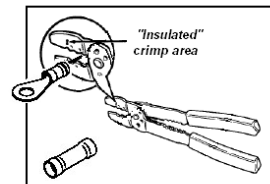
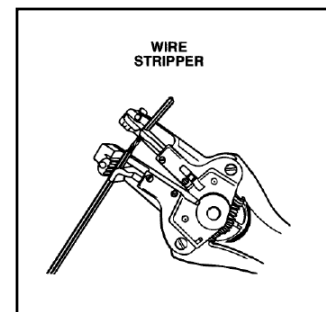

When using the kit crimping tool use the “insulated crimp” area of the tool as shown in the figure. Center the lug barrel on the proper die on the tool approximately at the 1/3-point closest to the stud end of the lug. Apply firm grip pressure. More pressure is usually needed for larger wires. Test the crimp by holding the terminal and tugging on the wire. The lug should not pull off.

- Over-crimping by using excessive pressure distorts the integrity of the wire strands and weakens the binding strength. Eventually the resistance of the joint will increase due to heating and chemical interaction and an unreliable connection may result.
- Careless positioning of the lug and wire in the crimping tool may result in a partial clamp of the wire at the tip, or a clamp on the wire insulation and not the conductors at the end of the barrel. Take your time and get it right. This is very important!

Crimp-on connectors that are improperly crimped may work at first, but can fail easily due to the operating vibration of a robot. Crimps fail if you push the wire so far into the terminal that when the crimp is made, it is only binding on the wire insulation and not on the wire strands. If the crimp is made with insufficient pressure, the wire will pull out easily. The real test is doing an ohmmeter continuity test on the lowest (R x 1) scale. Verify “0” ohms resistance from end to end of the conductor.

There will always be some controversy over practices and procedures. This is surely true when making “solder-less” connections. Solder-less terminal manufacturers consider that the highest levels of reliability are achieved using solder-less terminations. The SAE, (Society of Automotive Engineers) specifications highly recommend that all terminal lugs attached to 10AWG or larger wire should be first be lightly crimped on to the wire and then be soldered. This requires some knowledge and skill about applying solder and making quality solder connections.

If you choose to follow this recommendation, you will need a soldering gun or iron of at least 45 watts for soldering larger lugs and wires and a roll of rosin-core solder. The rosin core solder cleans the wires and prevents oxidation as it binds the wires in a flow of solder.

You should strip the insulation from the wire as before, so that, when fully seated in the terminal, the ends of the wire strands just protrude through the barrel. Then pre-tin the bared wire strands with a melted flow solder, assuring a good clear solder flow (silvery color). Slide the lug onto the wire and crimp the lug lightly with the crimping tool using the appropriate lug size crimp hole.

Then re-apply the tip of the soldering iron onto the junction of the wire protruding at the lug barrel and the lug barrel. Heat this junction, and using a strand of solder, flow melted solder into the junction observing the flow of shiny metal solder. Remove the soldering iron and hold the wire still to let the junction cool. The junction should remain metallic in appearance and not turn to a chalky white/gray in color.

G.6.1.6 Splicing Wires

Although you never want splices, it may be necessary at some point to temporarily extend a wire for a connection. An assortment of insulated or non-insulated butt connectors is available to make this job easier and more reliable. This drawing shows an example of a non-insulated butt connector being used to join two conductors. This type of splice is normally “crimped and soldered”.

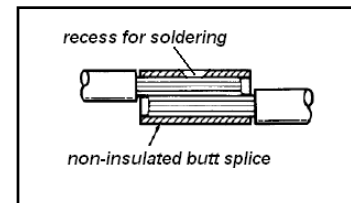

The junction should then be wrapped with electrical tape and covered with a length of shrink tubing for protection. Insulated butt splice terminals are frequently just crimped using the procedure described in the Wire Terminations paragraph above.

G.6.1.7 Labeling

When possible, take the time to label wires and devices. Down the road it will save time when modifying, troubleshooting, replacing components, and reconnecting wiring. Labeling can be done with heat shrink tubing or white electrical tape and a fine point permanent marker. If time permits, create a robot-specific wiring diagram for reference. The diagram and wire labeling will make it easier to trace and interpret circuitry during technical inspection and whenever resolving electrical problems.

G.6.1.8 Inspection

Be sure to inspect your robot's systems on a frequent basis following service work or when participating in an FRC event. Detecting and repairing minor damage to harnesses, individual wiring, or connections may prevent a future failure that could harm the power or control system or cause a robot to stop dead in the middle of a match.

WARNING

Please read the following sections very carefully. Failure to wire the robot properly could damage the control system and invalidate the control system warranty. FIRST and/or Innovation First will not provide free replacement of components damaged due to misuse or improper wiring. Teams will be required to correct wiring that is not configured according to the **2007 Robot Power Distribution Diagram** and according to the Control System rules in the Robot Rules section before being allowed to compete

G.6.2 12V Power System Overview

The 12V Power system consists of the 12Vdc battery, 120 Amp Main Circuit Breaker, DIN Power Distribution block, and the Circuit Breaker/Distribution panels. In all cases, please refer to the *2007 Robot Power Distribution Diagram* for specific guidance to wire the electrical system of the robot.

G.6.2.1 Locating System Components

When planning the layout and location of robot hardware and systems, priority placements should be given to the 12V Power system components as follows:

The 12Vdc Battery **must** be:

- Accessible for easy replacement and/or recharging and inspection. If, in the heat of competition and with a short time interval between matches you need to swap out batteries, having easy access will be worth its weight in gold.
- Firmly mounted but protected from contact by either the robot's own mechanical hardware or by other robots or field hardware. Batteries can be severely damaged if whacked by another robot.
- Be located as close as possible to the 120A Main Circuit Breaker, and to the Power Distribution DIN block to keep wire lead lengths as short as possible.

The 120-Amp Circuit Breaker *must be located:*

- Near the battery
- *In an accessible, protected area.*

Power Distribution DIN Block should be located nearby the 120-Amp Circuit Breaker to minimize the length of power wiring.

ATC circuit breaker/distribution panels placement for the best position to accept the incoming wiring from the distribution block and to route output wiring to loads. It also helps to have accessibility, protection, and convenience to service the panels whenever necessary.

G.6.2.2 12VDC System Assembly

FIRST supplies 4 Red Anderson Power Connector assemblies (red tote); one pair to connect the 12V battery to the rest of the Power Distribution system, the others are intended for the spare batteries. The Anderson connector provides a means of quick disconnect and exchange of the battery on the robot whenever necessary. In the Terminal Bag, SCRULUG lugs are provided to mate the #6 AWG cable to the battery posts.

The (Red) wire on the Input side of the Anderson connector must be connected directly to the Positive post of the ES17-12 battery. Tighten bolt. Finish by fully insulating the post with electrical tape.

The Negative (Black) # 6 AWG wire must be connected to the Negative post on the battery. Tighten the bolt. Finish by fully insulating the post with electrical tape.

Plasti-grip Ring terminals (1/4" 6AWG) are used to connect the opposite half of the Anderson connector cable to the Main 120 Amp Circuit Breaker BAT post and from the AUX post to the DIN Block.

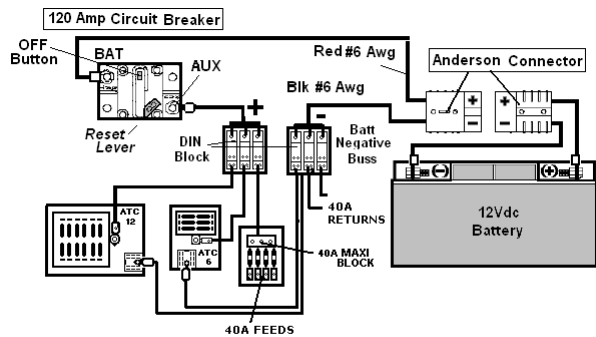

2007 Main Power Connections

WARNING!

Make a final re-check that the Red wire is on the (+) post and Black on the (-) post. Improper polarity can damage CONTROL SYSTEM components.

G.6.2.3 120A Circuit Breaker

The 120A main circuit breaker/disconnect switch functions as the Main Power **ON/OFF** switch for the robot and as a Safety current overload protection device.

To power down the robot power manually, push the Red **OFF** button on the breaker. To reset Robot Power to ON, push the **RESET** lever back into its nested position.

The Positive (Red) wire on the output side of the Anderson connector should have a 1/4" Ring lug crimped/soldered on and then be connected directly to the **BAT** post of the 120A main circuit breaker. Tighten the nut. Finish by fully pushing the rubber-insulating cap back down over the nut. This will assure that all power from the 12v battery now flows directly to the 120A breaker. Do not connect anything other than the 120A main circuit breaker/disconnect switch directly to the 12v battery's positive (+) terminal.

A fully charged 12Vdc battery can deliver current in excess of 200 Amps for a sustained period of time (minutes) in a short circuit situation. This amount of current can make wires smoke, melt through insulation in a fraction of a second, start a fire, cause the battery to leak highly corrosive acid or explode, and result in serious burns or other injuries. Always make sure that

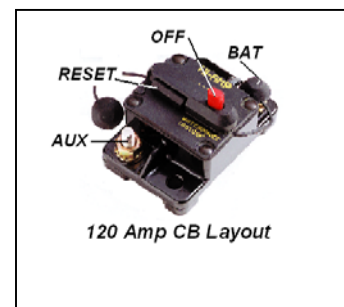

120 Amp CB Layout

the 120A main circuit breaker/disconnect switch is wired in series with the 12v battery positive (+) terminal and can break the circuit when necessary.

G.6.2.4 The ATC Fuse Panels

The Positive 12Vdc output of the 120 Amp Circuit Breaker typically is fed from the **AUX** terminal to the DIN Power Distribution block via a length of # 6 AWG (Red) wire. The output wiring (#12 AWG) is connected to the + Plus connection on the ATC panels. The battery negative connection from the ATC panel connects to the battery negative post on the power distribution block.

The 6 and 12-way ATC panels can hold a population of 30A, and 20A Snap-Action re-settable circuit breakers. The 20 and 30 Amp circuit breakers can be plugged into any available socket running the length of the panel. The Positive load wires are attached to the panel male tabs at the desired circuit breaker using the slip-on terminals provided in the Terminal Bag.

The Negative (Black) # 6 AWG wire on the output side of the Anderson connector must be connected to the GND Distribution block.

*The battery negative connection must **NOT be connected** to chassis ground.*

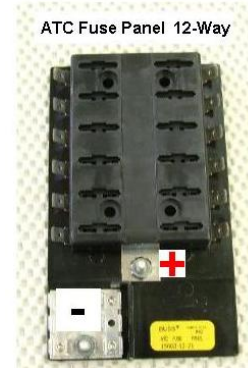

G.6.2.5 Maxi Style Fuse Block

The Maxi fuse block is used to support the 40 Amp service requirements of the larger drive motors. Up to four 40 Amp Snap Action circuit breakers can be fitted into the clips on the single Maxi fuse block shown here. If necessary, teams could use a second Maxi block for added 40-amp service. One end of the Maxi, the +12V feed block (top end in this photo), accepts up to three #6 AWG wires to distribute the +12V.

The load end of the Maxi provides 4 independent circuit feeds to the Victor 884 speed controllers. The negative wires of each load should be attached to the Battery negative side of the Power Distribution block.

Current ratings of the circuit breakers are the *maximum ratings* allowed. The AWG wire sizes to be connected to the different sized breakers are specified by the Rules as the *minimum AWG gauge* allowed.



G.6.3 Motor Power Distribution

Refer to the **2007 Robot Power Distribution diagram** to review the 12Vdc power cabling interconnections between the CB/Distribution panels and the V884 speed controllers or spike relays for various motors.

The sections that follow provide some practical guidelines, recommendations, and cautions regarding these interconnections. You will always find the specific wiring, programming, and operating details in the manuals for the various actuators available at the Innovation First web site at <http://www.innovationfirst.com>.

G.6.3.1 V884 Speed Controllers

The Innovation First Victor 884 speed controller is a specialized device primarily intended to control the 12Vdc power, direction, speed, and the braking/coasting actions of the larger (high current) motors associated with lift arm mechanisms and drive systems. Each speed controller

is rated for 40 Amps and must receive the 12Vdc power input from a dedicated 20A, 30A, or 40A circuit breaker on the CB/Distribution panel (depending on the output load). The wire size (AWG) to be used for each circuit breaker rating is specified in the FRC Rules.

You should download and refer to the **Victor 884 Users Guide** for specific information available at the Innovation First web site at <http://www.innovationfirst.com>.

The illustration shown here identifies the 12Vdc Power I/O terminals of the device and the polarity of the input terminals from the CB/Distribution Panel. They are located on the same side of the Victor as the PWM connection and per the polarity shown.

The motor output connections are located on the right side of the Victor with the polarity correct as shown. On the PWM cable, the Black wire side of the PWM plug is nearest the fan. The fans on speed controllers should be wired so the fan is always ON whenever the Victor 884 is ON.

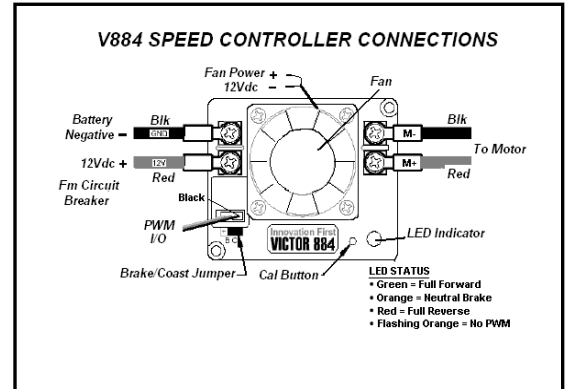

Be sure to connect speed controllers controlling high current motors such as the CIM and Fisher-Price motors to the 40A circuit breakers in order to maximize power output and prevent unexpected shutdowns. The Ring-type terminal lugs supplied in the kit, rather than fork lugs, should be used on both the 12V supply-side wires and the load feed wires to assure maximum surface contact and security of the connections for full power delivery.

Only one large motor (CIM, Fisher-Price, Globe or similar motor) should be controlled per speed controller. Although the speed controllers are normally wired to the 40A supply, they may be wired to the 30A circuit breaker outputs when connected to the Globe motors. In some cases, more than one low current small motor (window/Mabuchi) or actuator may be optionally connected to a single speed controller.

Control signals from the robot controller are communicated to the Victors via PWM cables. Make sure the PWM cable is plugged into the RCs and Victors paying attention to the wire color-coding as marked on the device flanges. The male end plugs into the Victor; the female end plugs onto the robot controller PWM Outputs.

Make sure the PWM cables will remain secured in place by using necessary cable ties and harnessing to anchor the cable. PWM cables may be grouped via a cable harness and routed separately away from the power cabling.

Warning!

Speed controllers will be damaged if reverse polarity is applied to their power inputs. Speed controllers may also be damaged if a short circuit occurs across the load output. It is very important, particularly at first installation, to verify that the DC polarity is correct and that a short circuit does not exist before applying any power to the devices.

For detailed information about calibrating speed controllers or setting the braking/coasting linking or mode for the motor by user switching, refer to the *Victor 884 Users Manual* found on the Innovation First website at: <http://www.innovationfirst.com>.

G.6.3.2 Spike Relay Module

The spike relay module provided in the KOP is typically used to control the OFF/ON operations of small motors and the forward or reverse direction of the motor output shafts.

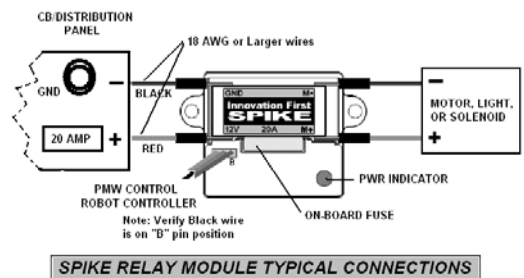

However, unlike Victors, they do not control or vary the speed of the motor. Spike relays also are used to operate solenoids or lights.

Since spike relay modules are rated to 20 Amps, it is recommended that they be used to drive only the smaller motors and actuators such as window motors, seat motors, solenoid valves, the air compressor, etc.

Spike relay modules must receive their 12Vdc input power via one of the 20A circuit breakers on the CB/Distribution panel at the input terminals marked **12V** and **GND**. While the terminal is marked as “GND”, this connection is to “battery negative” and NOT to chassis ground.). In some cases it is acceptable to distribute the main power from a single 20A circuit breaker to more than one spike relay module. The wire gauge (AWG) to be used for the spike relay circuit breaker is a minimum of 18 AWG specified in the Rules.

A single spike relay module can power no more than one motor. The motor would be connected at the **M+** and **M-** terminals of the relay module. The truth table (below) shows the M output signal status for the PWM signal input changes. Note that in the motor “OFF” state,

INPUTS		OUTPUTS		Indicator	Motor Function
Fwd	Rev	M+	M-		
0	0	+12v	+12v	Orange	OFF / Brake Condition (default)
1	0	+12v	GND	Green	Motor rotates in one direction
0	1	GND	+12v	Red	Motor rotates in opposite direction
1	1	GND	GND	Off	OFF / Brake Condition

the brake condition applies and the motor stops in the fixed position. In a simple program application, the relay module would supply **+12V** at the **+M** terminal and **GND** at the **M-** terminal for the **ON** state **A**.

If so programmed, the module can reverse the situation and supply **GND** at the **+M** terminal and **+12V** at the **M-** terminal for the **ON** state **B**.

The Truth table primarily applies to the control of motors for reversing motor direction. Other devices, such as the Thomas Air compressor, fans, and lights are intended to only be turned ON/OFF with the spike relay. The compressor motor should never be reversed, but only be connected and operated at the standard M+ and M- polarity input.

Under certain circumstances, it is acceptable to power more than one device from a single spike relay module. For instance, a single relay module might be used to power a combination of solenoid valves and/or fans in conjunction with a single window motor as long as their function is coincident. The spike relay module contains an on-board fuse rated at 20 amps. Still, it makes sense to limit the total load current through each spike relay module, lest you risk failure of a relay module.

Rules prohibit modification of parts and assemblies. Here is one exception:

When a spike relay is controlling the Thomas Air compressor, that 20A spike relay module on-board fuse may be substituted with a 20A Snap Action circuit breaker. However, this relay module must still be fed from one 20A circuit breaker on the CB/Distribution panel.

When the PWM cable is attached to the relay module, note that the black wire is placed onto the correct pin as noted on the module. The PMW cable must be then routed to the robot controller relay I/O ports and connected per programming requirements.

Warning

Attempting to drive a CIM, Globe motor or Fisher-Price motor directly with Spike relay modules could damage the modules and is, therefore, prohibited.

For more information about the spike relay module, interconnections and programming details, refer to the ***Spike Relay Users Manual*** available on the Innovation First’s website at: <http://www.innovationfirst.com>.

G.6.4 Sensors

In general, the robot controller anticipates receiving inputs from sensors either in the form of contact closures (digital) such as those from a gear tooth sensor, or as 0-5V voltage levels (analog) at its input ports. In the case of analog signals, the robot controller supplies 5Vdc at 1 Amp for the analog inputs. As there are 7 input possibilities, each port should be limited to approximately 50ma. The input types, a combination of potentiometers, accelerometers, and gyro (yaw) rate sensors, should present high impedance to the analog input. All potentiometers must be 100KΩ.

Typical wiring configurations for various analog sensors, switches and other devices to the analog or digital input terminals on the robot controller should conform to the Pin out and software function schedules included in the Innovation First, Inc. 2007 Robot Controller Reference Guide at: <http://www.innovationfirst.com>.

WARNING!

Do not connect switches to the +5v Output Pins of the robot controller. The +5v output pins are intended to supply a fused 5Vdc AUX power for use by analog sensors.

Do not connect any other voltage to the analog inputs on the robot controller. It may damage the device.

This year's Kit of Parts provides an interesting assortment of sensors and software tools to help teams develop a very competitive robot. In particular, the game relies on advanced robot control by Vision system sensing and direction control of the robot platform. A good place to start is a discussion of the CMUCam2 and the Vision system.

G.6.4.1 CMUCam2 Vision Sensor

This year's game again features robust on-board CMUCam2 Vision sensing (color-tracking camera) and programming to accomplish specific locating tasks during the game.

The CMUCam2 components supplied in the Electronic Kit include the CMUCam2 Lens module, the Main Control PCB assembly, the TTL PCB, and a pair of Hitec HS-322HD Servomotors, and a Pan/Tilt Bracket kit assembly for camera positioning control. The hardware allows the camera to efficiently track a target and control the robot to maintain lock to the target. The key to realizing efficient tracking lies in skillful software programming of the control system. Here's where the fun begins.

The 2007 kit continues to provide the **MPLAB CBOT Compiler** software for text base programming in the ANSI C programming language and includes the MPLAB C18 compiler. New libraries for the sensors and camera are available to help programmers working in the IDE format.

Another alternative again this year is the development and use of the GUI (graphical user interface programming tool by Intelitek for the 2007 FRC called "**EasyC™ Robotics Design System**". This GUI programming tool includes all the code for the new sensors in this year's kit and is available for download by 2007 **FIRST** teams following Kickoff.



An additional software from National Instruments, a graphic-based software called **NI LabVIEW 8 Students Edition** for testing, measurement, and control, is also provided in the kit. Sample applications are included with LabVIEW to analyze and calibrate the CMUcam2 Vision sensor, perform motor performance simulation testing, and a virtual instrument to process and display data from the Operator Interface dashboard. These softwares include significant advancements and a great head-start opportunity for teams in getting ready for competitions.

The *FIRST* website offers downloads for Vision system set-up. The **2007 CMUCam2 Setup and Initialization** guide provides essential configuration, setup, and operational information to get the basic camera feature going on your robot. This document is also included in the **2007 CMUCam2 Workbook** and in a package of documents and programming code for the **Vision Sensor 2007 FIRST Robotics CMU Cam2 Vision Documents** on the *FIRST* website at <http://www.usfirst.org/community/frc/content.aspx?id=4054>.

The general camera interconnection diagram (shown here) gives the PWM cable interconnections made from the camera PCB to the Controller. Teams should download the Vision system documents for the detailed assembly, interconnection, and diagram information.

The camera assembly receives DC power from the robot controller 7.2V back-up battery via PWM cable interfacing. The robot controller receives the CMUcam2 signals via the TTL-232 Converter PCB plugged into the RC TTL Serial port. The RC unit sends control signals to the Pan/Tilt servos as necessary to aim the camera to the target.

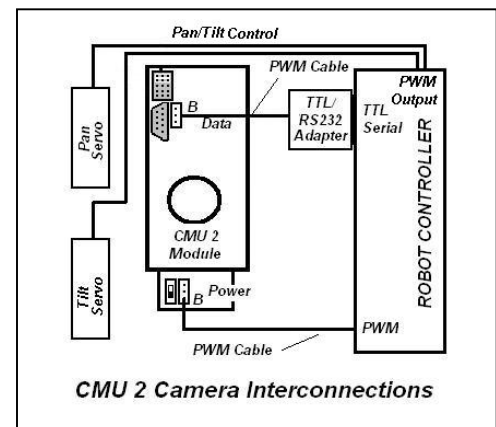

G.6.4.2 Sensor Modules

Along with the 2007 KOP each team will receive a Sensor bag containing 2 Gear Tooth sensor modules (shown below) for use in the 2007 game. The Gear Tooth (GTS) sensors feature the *ATS642LSH* Hall-Effect IC from Allegro Microsystems pre-packaged onto a PCB interface module for your convenience.

Two other sensor modules, a Dual Axis Accelerometer (DAA) and a Yaw (angular) Rate (YRG) sensor module (from Analog Devices) will be supplied immediately following kickoff.

The PCB modules are designed to permit standoff mounting using appropriate hardware. Note that plastic washers should always be used to isolate the PCB from chassis contact.

The 2007 Kit includes eight 3-foot PWM cables. Normally the PWM cables are consumed in robot construction when interconnecting Victor 884 Speed Controllers, Spike Relay modules, and well as the many other sensors you may install aboard the robot (such as the CMUcam2 camera and pan/tilt servos described above) to feed the robot controller. Depending on your robot design, several extra PWM cables should be on the top of your shopping list to request from Innovation First early in the build program, as each of these additional sensor modules typically will each require a pair of PWM cables.

General technical information on the sensors can be found in the **2007 FIRST Robotics Sensor Manual** at <http://www.usfirst.org/community/frc/content.aspx?id=4054> and more specific info on the individual device specification and application datasheets.

G.6.4.3 Gear Tooth Sensor

The *ATS642LSH Hall-Effect IC* is used for detecting and counting magnetic fields from ferrous gear teeth related to a robot's drive operations. An example is counting teeth on a gear to measure and control speed traveled. The device output is a PWM digital signal at a nominal 45 μ s pulse period for forward or reverse rotation out of the "S" port. This speed sensor is self-calibrating, adept at handling vibration, and is immune from air gap variations.

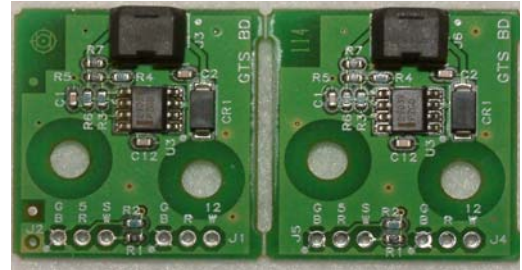

Two PWM cables are needed to interconnect the module. One cable is used to supply a 12Vdc operating voltage from the sensor distribution circuit breaker. The second PWM cable connects to an available digital input port on the robot controller to deliver sensed pulse counts from the "S" port and to receive +5V from the RC unit. "G" is always the ground connection

A complete technical data sheet is available for download for the **Gear Tooth Sensor** on the *FIRST* web site Specifications documents at http://www.usfirst.org/robotics/doc_updt.htm.

Just a note here that you should make it a check-off item and a standard practice to periodically inspect and clean the Hall-Effect sensor of any ferrous debris particularly following fabrication and mounting of the sensor assembly, periodically prior to robot testing, and/or certainly before any competition.

G.6.4.4 Accelerometer

Another very useful sensor is the rugged Dual Axis Accelerometer provided by Analog Devices (P/N ADXL311). The accelerometer measures both dynamic motion (vibration) and static motion (gravity). It is ideal for tilt (or orientation) and motion sensing measurements. The device provides high-resolution measurements along an X and Y oriented axis. The output signals are analog voltages proportional to the sensed level of acceleration both positive and negative at a magnitude up to +/- 2g for each axis.

Analog values can be with the User Processor's A/D inputs. Use the GET_Analog_Value routine found in ifi_utilities.c. The results will range from 0 (0 volts) to 1023 (5.0 volts).

The Accelerometer is most sensitive to "tilt" when its sensitive axis is parallel to the earth's surface (or perpendicular to the earth's gravity field). For example, in this orientation the output changes nearly 17.5 mg per degree of tilt up to an angle of 45° where the resolution declines to 12.2 mg per degree. The accelerometer module is powered from 5VDC via two PWM cables.

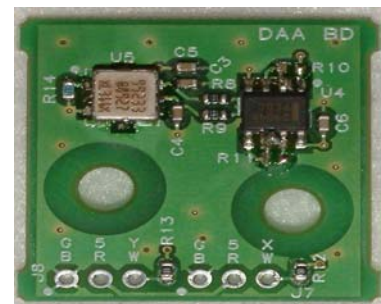

A complete technical data sheet is available for download for the **DAA -Dual Axis Accelerometer** on the *FIRST* web site Specifications documents at http://www.usfirst.org/robotics/doc_updt.htm

HANDLE WITH CARE!

Accelerometers are extremely sensitive to rough handling. Simply dropping the module on the floor could generate several thousands "g" of acceleration, exceeding the absolute maximum limits of the device, and possibly destroying the device.

G.6.4.5 Yaw Rate Gyro

The *ADXRS150* Yaw Rate Gyro senses angular changes about the top surface axis of the device and provides an output voltage proportional to the angular rate change. The output is useful for guidance, stability, and control of the robot platform.

One thing to keep in mind as you are laying things out on the robot and using the Yaw Rate Gyro sensor module is that the lowest apparent drift on the gyro will occur when the module is mounted flat in or near the center axis of the robot's rotation. The figure below indicates the rate change increase for clockwise rotation.

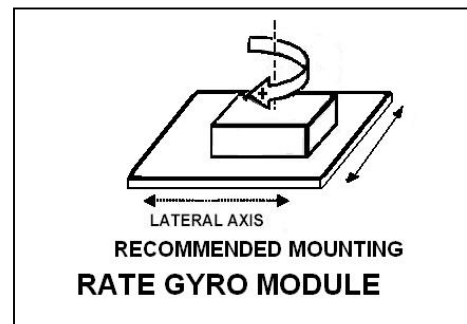

When mounting the YRG module, use nylon washers to isolate the PCB from the chassis.

Use two PWM cables to connect from the module BRW terminals to the robot controller analog inputs. The color code for the cable is shown on the figure above with “black” on the left, “white” on the right, and red in the center. The Yaw Rate gyro receives 5V from the RC and connects to two of the robot controller’s analog inputs.

The “T” output is a measure of twist or rotational acceleration. The “T” output will increase with clockwise rotation. “No rotation” at the “T” output produces 2.5Volts. Accelerating cw produces a voltage above the 2.5 V. The “T” output varies at approximately 12.5 millivolts per degree per second.



The “R” output is a measure of relative temperature. The “R” output varies by 8.4 millivolts per degree Kelvin. A temperature of 298K (about 25°C) will give an analog value of 2.5V. A cooler temperature provides lower voltage at “R”.

A complete technical data sheet is available for download for the **YRG- Yaw Rate Gyro sensor** on the *FIRST* web site Specifications documents at http://www.usfirst.org/robotics/doc_updt.htm

G.6.5 Custom Circuitry

It is not possible for *FIRST* to test all custom circuits other than as specified in the Rules. So, we rely on all teams to use Gracious Professionalism (and good engineering) when building and implementing custom circuits in their design.

Please read the *Control System* documentation from Innovation First for information on the robot controller sensor inputs. Support by *FIRST* and Innovation First for additional electronics and custom circuits is limited to the documentation provided in your kit and that which may be found on the Innovation First website.

G.6.6 The Robot Controller

The robot controller (RC) typically gathers and organizes information from the Operator Interface Unit and from the connected on-board sensors, determines the action or functions the robot should be performing, and operates the necessary actuators to perform the required work. The controller also sends essential performance data to the Operator Interface to alert the operators of the robot performance status and issues and to aid operators in deciding tactical operations.

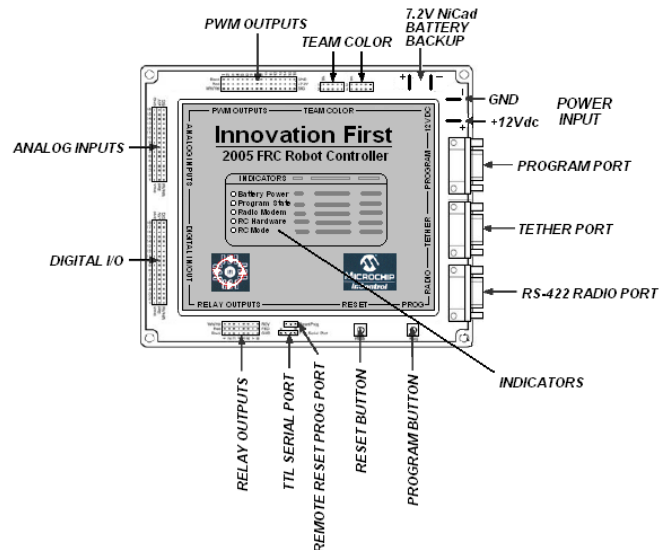

The RC provides a group of 5 LED indicators on its front panel to indicate the status of battery power, program run, radio modem communication, RC hardware operation, and the current RC Mode (enabled/autonomous/ or disabled).

As you can see, the RC provides a number of interconnection possibilities around the perimeter of the module. It is a high probability that most of these ports and controls will be in use on your robot. The objective of this section is to familiarize the reader with the general interconnections and useful considerations for installing and interconnecting the RC to the actuator devices and sensors on-board the robot. For specific interconnection details, refer to the **2007 Robot Controller Reference Guide** at: <http://www.innovationfirst.com>.

G.6.6.1 Locating the Controller

Remember that the Rules specify that the RC must be mounted on the robot in such a way that the LED indicators on the front panel are clearly visible. In addition, easy access to the tether connection and to the Reset button should be provided since frequent use of these facilities is certain. Typically the RC will be located under a protective acrylic panel. In deciding the location, also consider the routing of the various PWM cables and sensor cables. Keep in mind that these cables should be kept somewhat isolated from the motor & solenoid power cabling and firmly harnessed together to reach the RC via an efficient route.

G.6.6.2 Power Input Connections

As a reminder, the robot controller power wiring must come directly from the CB/Distribution panel via an independent 20 Amp circuit breaker. The wires must be a minimum of 18 AWG and the conventional color-coding of wires must be used for wire pair as stated in the Rules. Use slip on terminals to complete the interconnections at the location shown in the diagram.

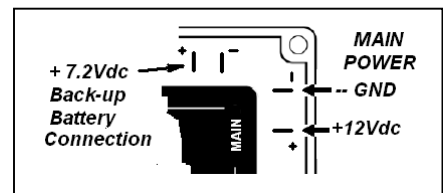

G.6.6.3 Robot Signal Light

Once the Signal light is mounted on the robot (see Section G8.1), the PWM cable from the light relay socket is routed to the RC unit and connected to any one of the (four) Team Color 5-pin plugs labeled 1 to 4

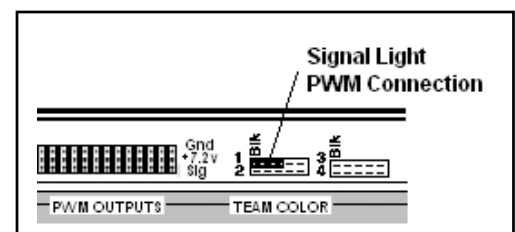

as shown in the figure. Note the location of the “Blk” stamped on the RC and be sure to plug the PWM cable with the Black wire onto the “Blk” designated pin. Also, be sure to properly secure the PWM cable harness to the robot framework so as to protect the wires from potential damage or inadvertent disconnection.

The Signal light will be lighted at power on and indicate the robot operation status during the match.

G.6.6.4 7.2V Back-up Battery

The 7.2V NiCad battery, connecting cable with plug, and a 7.2V charger module are provided in the KOP again this year. The battery must be connected to the RC at the 7.2V NiCad Battery connection (shown on the power input diagram above). The 7.2V battery does provide backup electrical power to the RC during low input voltage conditions that can occur in the robot’s 12V Main power circuit. However, it also is the source of power for the new CMU Vision sensor as well as servos connected to the PWM outputs of the RC.

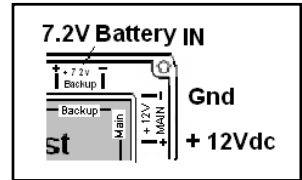

The team should plan on buying extra 7.2V NiCad back-up batteries so a fully charged battery will always be available when required for competition. You may use a larger capacity 7.2V Battery in place of the battery provided in the kit. For information about the 7.2V NiCad Battery specifications, please refer to Innovation First’s Control System documentation on their website at: <http://www.innovationfirst.com>.

G.6.6.5 Digital and Analog Inputs

The Controller provides 16 digital and 7 analog Input ports for connecting to various sensors. Digital inputs are provided by switch open/closures. The analog input ports are used to receive inputs from analog sensors and potentiometers of a voltage that ranges from 0 to 5V relative to some position or event of the Robots’ mechanisms. User software code programmed to the RC will set the intended output action for all sensor inputs.

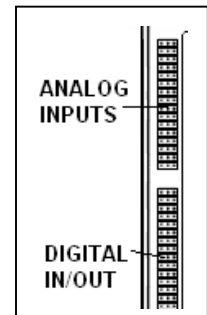

G.6.6.6 PWM Output Ports

On the output side, the Controller is fitted with 16 PWM outputs ports used primarily to control Victor 884 speed controllers. The PWM signals are derived from joystick operations at the Operator Interface unit (OI). The variable pulse width modulation signals activate the Victor to turn drive motors OFF/ON, enable forward or reverse modes, and operate motors at variable speeds.

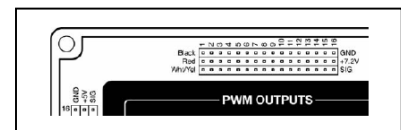

The PWM ports supply 7.2V to the CMU2 Vision sensor, miscellaneous servos and to the Victor devices.

G.6.6.7 Relay Outputs

The Relay outputs are also used to control spike relay modules, which operate various small motors in OFF/ON and forward/reverse modes. Spike relay modules also operate the air compressor and pneumatic solenoids.

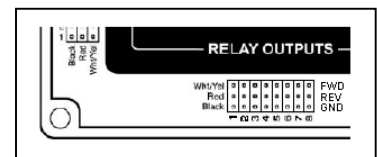

The relay output connection block is the termination point for the PWM cables from the spike relays. The RC User or Custom program will set the spike relay operations as determined by

operator control of joysticks or switching inputs, or as is determined by on-board robot sensor inputs to the RC processor.

G.6.6.8 TTL Serial Port

The Serial port enables the receipt of RS-232 serial data into the RC unit. This port is used to input the RS-232 data from the CMU camera via the TTL to RS232 Converter interface PCB assembly. This connection is described in the “*Start Here*” *Vision Sensor Guide* which is part of the CMUcam2 Zip file at <http://www.innovation first.com/>.

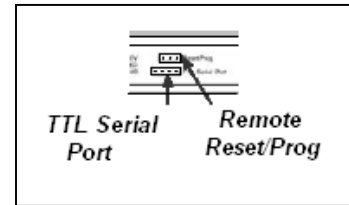

G.6.6.9 Reset/Prog

This connection can be used in place of the on-board buttons to input a switch closure for performing a remote RC reset or to enable the RC to accept programming downloads from a PC.

G.6.6.10 Reset Button

The Reset button should be pressed at each power-on to perform a complete hardware reset of the RC and restart the RC processors. A reset also causes the external radio to go into a channel “search” mode.

G.6.6.11 Program Button

The PROG button is intended to stop the User program from executing and to await a download from a PC. The button is necessary when programming via some PC serial ports. When activated, a solid yellow light appears at the “program state” LED.

G.6.6.12 Radio Modem

This connection accepts the plug of the 6 foot DB9 cable which interconnects the external RS-422 Radio to the RC unit. Generally the radio is the last item mounted on the robot. It should be mounted in the vertical position securely. Excess interconnecting DB9 cable should be coiled and secured in an isolated area of the robot frame away from other cabling to prevent pick-up of cross-talk interference. It is strongly suggested to use only the supplied cable to maintain shield and signal integrity.

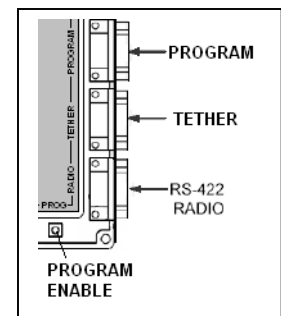

G.6.6.13 Tether

This plug allows the Operator Interface (OI) to be plugged directly into the RC for communication and control testing. When a tether is used, power for the OI is supplied from the RC 12Vdc supply. Radio modem communication is not required nor enabled in the Tether mode.

It is strongly suggested to NOT leave a pigtail on the tether connection during competition as any picked up interference could change robot operation.

G.6.6.14 Program

The Program port is primarily used to enter new user code into the RC unit. Initially the RC contains a default program, which is sufficient to provide basic robot operations. This code can

be replaced with a custom program created by the team following Innovation First guidelines. The Program port may also be used as the second serial input port for the RC to monitor the CB/Distribution panel operation, or to support custom circuitry.

It is strongly suggested to NOT leave a pigtail on the Program connector during competition as picked up interference could change robot operation.

G.6.6.15 “Stuck” Robot Controllers

Once in a great while a team may see the following symptom, which appears as if their full-size robot controller is "stuck" following a USER program download.

Cause: The problem appears to occur when a PC corrupts the serial port timing. USB-serial converters are more susceptible. If this problem continues to re-occur, try downloading the User code from another PC.

Identifying Problem: The "Battery Power" LED blinks green, the "Program State" LED is solid yellow, and all others are dark. Resetting the RC does not clear it. Code will download, but it will not run. Your RC will not link to an OI.

Solution: Follow the procedure below with power applied to reset the RC unit from this “stuck” state:

1. Press and hold the **RESET** and **PROG** buttons at the same time.
2. Release **RESET**; continue to hold **PROG** until the "Battery Power" light becomes a solid green.
3. Release **PROG**.
4. Hit **RESET**.

You should be operational again and able to link with an OI. You may now download new User code if required.

G.6.7 Operator Interface

The Operator Interface is intended to communicate via two-way radio modem to a remote robot controller. The input from joysticks, buttons, custom control boxes, or any other input device at the Operator interface is communicated to the robot to control its operation. Feedback from the robot is relayed to the OI and monitored at the operator station.

The exact wiring configuration for the joysticks, switches, potentiometers, LEDs, and analog sensors connected to the Operator Interface is not specified here, but can be found in the **FRC 2007 Operator Interface Reference Guide** at:

<http://www.innovationfirst.com>

Teams may wire these devices, within the rules as described below and according to the documentation supplied by Innovation First, in order to create a custom interface for the robot operators. Note that sensor load limits may apply when several devices are to be connected to the OI unit.

Although not a requirement, it is suggested that teams use a project

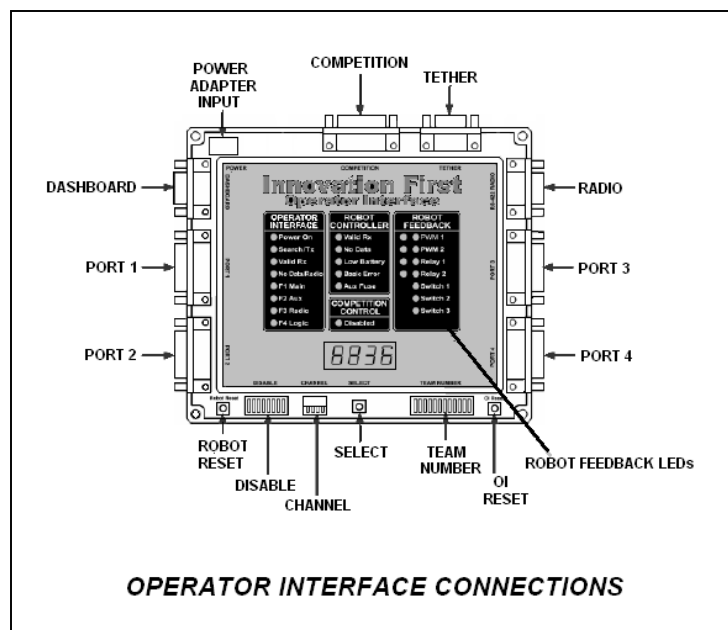

box as a housing for the switches, potentiometers, LEDs, and sensors. When using a project box, wire all components to the 15-pin male connector(s), mount the connector(s) onto the project box, and use the 15-pin molded cable(s) to make the connection(s) to the Operator Interface.

The LEDs may be connected between +5Vdc and Ground or between an LED output and Ground to serve as a visual indicator to the robot operators. This can be helpful during a competition match when a robot operator may not have a good view of the Operator Interface.

Caution

Connect switches between a Digital I/O Signal and Ground. Do not use lighted switches with the Operator Interface unless the switch light circuit is disabled.

Warning!

Do not connect switches to the +5Vdc fused Aux Pin (Pin 1) of the Input ports of the Operator Interface. It may damage the switches. Pin 1 is intended to supply fused 5Vdc power for use by analog sensors and potentiometers.

Any analog sensor must be connected to +5 Vdc Aux, Ground, and an analog input. Potentiometers must be connected to +5 Vdc Aux and an analog input. All potentiometers should be 100KΩ. Due to the special nature of the analog inputs on the Operator Interface, connecting potentiometers to Ground is optional but *not required*. See the Innovation First documentation for more information.

Figure 5.3 shows an example of the proper way to connect a switch, potentiometer, LED, and yaw rate sensor to the **Operator Interface**. Port and Pin designations shown in Figure 5.3 are merely examples and will vary depending on the number of devices connected.

Potentiometer

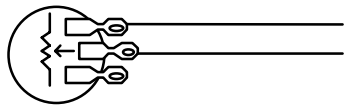

Port 3

Pin 1 (+5 Vdc)
Pin 3 (Port 3 X-Axis)

Rocker Switch (Typical)

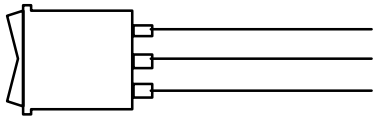

Pin 10 (Port 3 Aux Switch Input 1)
Pin 4 (Ground)
Pin 14 (Port 3 Aux Switch Input 2)

LED (any color)

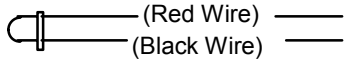

Pin 15 (Feedback LED - Relay1 Green Output)
Pin 12 (Ground)

Yaw Rate Sensor

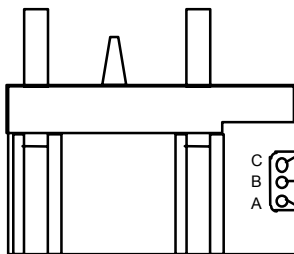

Pin 11 (Port 3 Aux Analog)
Pin 4 (Ground)
Pin 1 (+5 Vdc)

Figure 5.3: Connection Examples for Operator Interface

G.6.7.1 General Hookup & Powering

There are three ways that the Operator Interface unit may be powered up. They are:

- Using the supplied AC adapter.
- By a tether connection directly to the robot controller
- Via the Competition port

The AC adapter provides the correct output voltage and current to operate the Operator Interface unit from the 115Vac 60Hz power available. When tethered, the robot battery will provide the system power. When competing in the practice, qualification, or elimination rounds of a competition, the Competition port provides the control power.

Other connections to the OI typically include a pair of joysticks.

G.6.7.2 LEDs & Displays

The Operator Interface features a highly visible indication system for system integrity and to alert the operator of system malfunction. Typically, the operator views the Power ON and “Valid Rx” LED indicators between the robot and the OI. In the event of a failure such as the loss of communication data, a low battery level, detected data errors, or a blown fuse, steady or blinking LED lights will warn the operator.

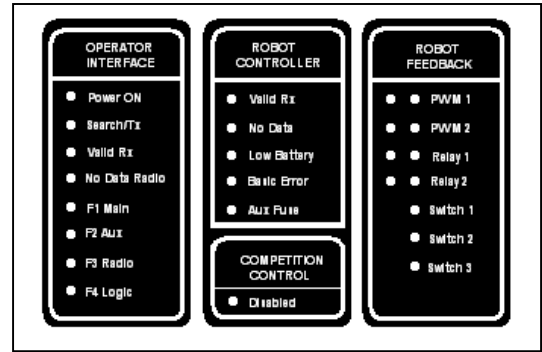

The Competition Control Disable LED indicates one of three states will exist when illuminated: Disabled, Autonomous, and Enabled. If the LED is ON solid it indicates that the robot controller PWM and relay outputs are in the “disabled” mode and the robot is “dead” This occurs at the start of a match or when the robot has been disabled by an E-stop in a match for protection. When the LED is blinking, it is indicating that “Autonomous” mode is active, and the robot is under the control of the Autonomous programming. If the LED is “OFF”, then the robot is in the “Enabled” mode and is under driver control.

G.6.7.3 Team Number

The team number is a most important entry made directly on the Operator Interface. The Team Number DIP switch is used to set the binary value of the team number by closing selected switches along the 12- position switch assembly.

Team Number	0000
Channel Number	c40
Robot Voltage	12.3
User Mode	u000

Step 1 is to press the **SELECT** button to sequence the readouts to display the row of “0000” (4-digit readouts intended for the team number). When “0000” is displayed, enter the team number by pressing down the highest binary- numbered switch less than the team number. Calculate the difference and close the switch less than the difference value. Continue until you have the correct team number displayed on the readouts. Attach the tether cable to the RC unit to download the new team number information to the robot. The RC unit will store the number to EEROM memory.

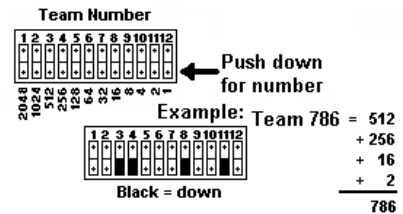

G.6.7.4 Dashboard Port

The Dashboard Port may be used to provide output information from the Operator Interface to a PC. The data may be the data sent from the robot or the data sent from the OI out to the robot. Innovation First offers a Windows™ compatible Dashboard Viewer software program for use in viewing the data on a PC. The data type is selected by moving a jumper on the OI between OI and RC.

Teams assume all risk associated with use of this program and/or data collected from the Dashboard port. For more information, consult the Innovation First website at: <http://www.innovationfirst.com>

G.7 ROBOT PNEUMATICS

This pneumatics section is intended to give introductory information on how a pneumatics system could be useful in operating various mechanisms on your robot. Teams should be familiar with the **2007 FIRST Pneumatics Manual**, available for download at <http://www.usfirst.org/>. This document provides comprehensive information about installing the pneumatic components. The manual also includes information about the ordering process for additional air cylinders and actuators.

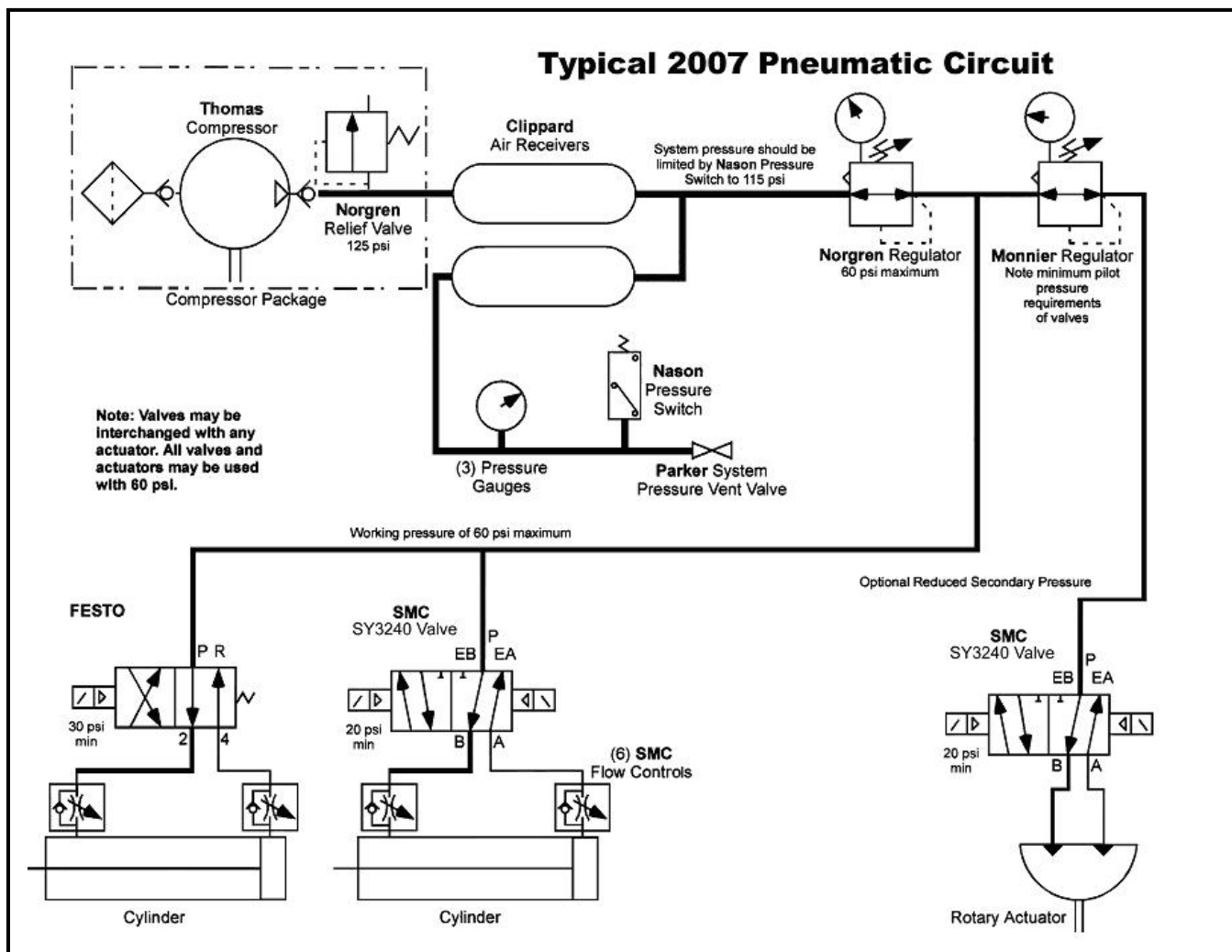

Teams utilizing pneumatics may choose to not use an on-board air compressor but simply charge up the bank of Clippard storage tanks with compressed air for pneumatic functions prior to entering the playing field. When the compressor is not fitted, the on-board pneumatic system must still include the 60-psi regulator, the 60-psi pressure gauge, and relief valve.

The figure below shows a diagram of a typical Pneumatics System that may be configured from pneumatic components supplied in the FIRST KOP. This system converts electrical energy into highly pressurized air (pneumatic energy) via a compressor, which is stored in air volume tanks. Whenever the robot controller programming requires air energy, it is delivered via the high-pressure tubing to a selected solenoid-controlled valve to operate a cylinder to perform work for the robot.

G.7.1 Component Definitions

Thomas Compressor - The compressor operates from the 12Vdc battery and, when turned ON/OFF by the controller signals, will charge the Clippard air volume tanks to 125psi.

Norgren Relief valve - Limits the compressor output to 125psi.

Vibration Isolators - are provided in the kit to shock-mount the compressor, which, during air charging, will vibrate significantly.

Clippard Tanks – Two tanks are provided in the 2007 KOP and may be used to store and provide a steady volume of 125 psi compressed air to downstream regulators and actuators. Up to 4 Clippard volume tanks may be used on the robot for this year's game.

Nason Pressure Switch - Monitors the stored air pressure. The Pressure switch sends signals to the controller to start and stop the compressor to maintain the pressure.

Wika Pressure Gauges – Located on each regulator and on the high-pressure line, **pressure gauges are required to be installed** in your pneumatic system to display the 60psi (working) and the 125psi (storage) pressures. The third gauge showing the secondary regulator “psi” value is not required, but recommended.

Optional Pressure Transducer – Sensor outputs voltage proportional to air pressure to report air pressure status to custom circuitry.

Parker Vent Valve – The Vent valve is a **required safety component** used to bleed all air pressure from the air storage tanks whenever the system is not in use.

Norgren Regulator Valve – The Norgren Regulator valve **is a required component** that must be mounted in line directly after the storage tanks and is adjustable to limit the “working” air pressure of the system to a maximum of 60psi.

Monier Secondary Regulator – The secondary regulator is located after the Norgen 60psi Regulator connection and allows for a lower pressure pneumatic leg if needed.

Solenoid Valves – The solenoid valves electrically control the position of mechanical valves to steer air into the cylinders and drive or retract the cylinders in the desired direction. In the KOP four valves are “single” solenoid operated. When these solenoids are not energized, the solenoid is spring actuated to set the valve rod to retract the cylinder. When the solenoid is operated, the valve rod will be electromagnetically driven to change the airflow port direction. The air will then drive the cylinder into its extended position until the solenoid is de-energized. Then spring pressure resets the valve rod to vent the air and retract the cylinder.

In the figure above, all solenoids are shown in the de-energized state. The arrows indicate the direction of airflow from the P (pressure) line to R (return). When energized, the arrows are shifted to the right and the airflow will now be supplied in reverse direction to the cylinder.

Two SMC “12V Double” solenoids are provided. A “Double” solenoid has a pilot solenoid coil on each end of the spool assembly. By pulsing one coil and/or the other, you can control the air direction and, as a result, the amount of extension or retraction of the cylinder at will. When power is removed, the cylinder remains in a fixed position until the manual overrides are activated to release air pressures.

BEST BET: On a double solenoid, energize only one solenoid at a time!

Air Cylinders & Actuators - The Pneumatic System drawing shows linear air cylinders and a rotary actuator that could be used. You can order up to three more (cylinder/rotary actuator) devices supplied free using the order form in the *FIRST Pneumatic Manual*. Besides free components, you may use additional solenoid valves and air cylinders or rotary actuators. However, they must be identical to those listed on the Pneumatic Components Order form, and obtained from a Bimba or Parker Hannifan distributor.

Flow Control Valves - Above each end of the linear air cylinders, is the graphic symbol for a Flow Control valve. These adjustable valves (mounted on or as close to the cylinder as practical) permit free airflow from a solenoid valve to a cylinder, but control the exhaust airflow rate from the cylinder, thus slowing its mechanical action in returning to the relaxed state.

G.7.2 Pneumatic Electrical Distribution

The figure below shows a simple electrical connection diagram of the power, sense, and PWM control wiring of the pneumatic actuator components. In reality, more pneumatic components may be used in your system, but they will essentially conform to the connections as depicted below and according to the electrical distribution drawing included at the end of this section.

G.7.2.1 Tips on Assembly

Air Compressor - Be sure the air compressor receives 12Vdc power from its own spike relay. We recommend the spike relay be operated from a 20-amp Snap-Action circuit breaker.

Nason Pressure switch - The Nason Pressure switch must be wired via a PWM type cable directly back to the robot controller digital input port. The robot controller, when programmed, controls the ON/OFF switching of the compressor spike relay.

Do not wire the pressure switch in series with the compressor power lines. Even if the relay could be operated this way, the switch cannot handle the starting current of the compressor.

Teflon Tape & Fittings- all threads on male fittings require Teflon tape to seal properly. Start by wrapping the tape around the fitting leaving the first two threads bare and in the direction of the threads. This is because the fittings are tapered, and should the tape become loose at assembly, it will not block the valve opening.

Tubeing – One thing will become apparent. Tubeing that is too short will likely make an unreliable connection. Allow for flexible bends in the tubeing as necessary.

Cut tubeing with clean perpendicular cuts. Slide tubeing fully into the Quick Connect fittings. Press down on the release ring to remove the tubeing if necessary.

Cylinder – Assure the load on the cylinder is connected before operating the device.

Leaks – Once the pneumatic connections and electrical interconnections have been made, the system should be tested for charging air to the pressure values assigned by the Rules for the primary and secondary legs of the system. Close the Norgren Relief valve. Run the Thomas compressor to the 125-psi pressure. At 125 psi the compressor should shut down. The regulators should then be adjusted as necessary to the 125 psi and 60 psi values permitted.

The system pressure should remain intact until a solenoid has been activated. If the pressure is deteriorating without any solenoid operations, the system must be checked for leaks and the faulty coupling repaired, usually by fixing the Teflon tape seal. Open the Norgren relief valve and confirm the system pressure decays to 0 psi before disconnecting any couplings to effect repairs.

When the system pressure test is completed, release any stored air pressure by opening the Norgren relief valve, observing the system pressure decays to 0 psi.

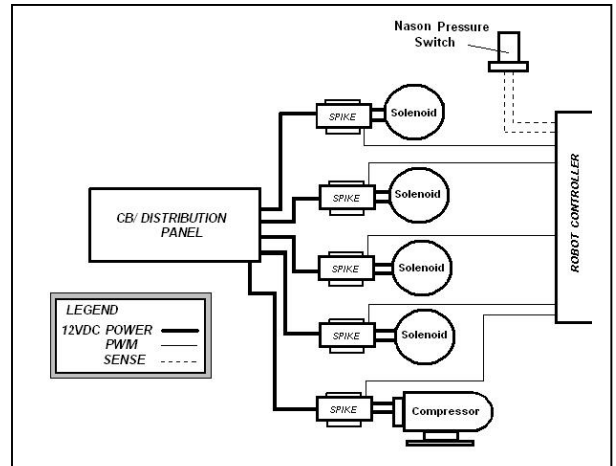

G.7.3 Using Vacuum on the Robot

Although the use of vacuum devices has been allowed in the Rules for a number of years, the 2007 KOP supplies teams with a compact vacuum pump, and vacuum cup, tubing, and a fitting (provided by Piab) that could be useful in this years game. The pump is a miniature inline type typically mounted between a compressed air source and a vacuum hose.

G.7.3.1 How it works -

A vacuum is developed whenever compressed air (1) is passed through the vacuum pump ports (exits at 2). The compressed air draws along some air from port 3 through the one-way valves. This air “loss” results in a vacuum level being drawn at port 3. Ultimately, the vacuum level developed will depend on the applied compressed air pressure. The ideal air pressure with this hardware for most small applications would be around 27-psi.

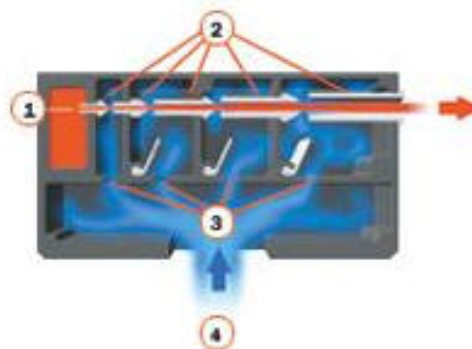

The vacuum generated at the output port (3) can be connected via a short length of 4mm tubing to the vacuum cup. When the cup is placed over a fairly flat surface, the vacuum will collapse the cup onto an object’s surface. The mechanism carrying the cup then can pick the cup and object up and transport the object being held by the cup while the vacuum pressure is present. Releasing the vacuum pressure on the cup drops the object.

Best Bet: Keep the vacuum pump as close to the vacuum cup as possible for the most responsive grip at the lowest vacuum pressure. This means keeping the 4mm vacuum tubing line short for maximum control of the object to be transported.

Piab also makes a DIN Rail Adapter (P/N 01.10.145 - Order from Piab) which includes the necessary hardware to mount the 2010 Vacuum pump directly onto a piece of the 35 mm DIN rail supplied in this year’s kit.

G.8 THE FINAL TOUCH

G.8.1 Signal Light

This year the Kit of Parts contains 1 Hi-Intensity LED Amber Signal light. Each team is responsible to install the signal light onto their robot. It must be mounted on the robot such that it can be clearly seen from the front of the robot when in its starting position. The light indicates robot status and is used for diagnostics during the match by field personnel.



The LED light is supplied in the KOP together with a solid-state relay and a DIN-mount relay socket. The socket terminals are numbered for simple connection. A PWM cable is required to complete the interconnection to the RC unit, which provides all signal control to operate the light. The wiring diagram shows the interconnections necessary for operation.

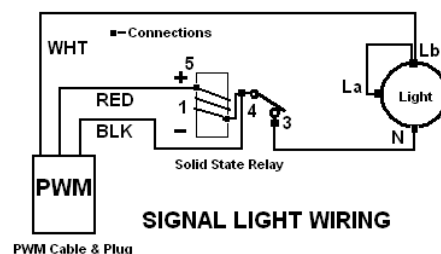

The Signal light base is intended to attach to a bracket having a 22mm hole. A nut is provided to secure the light assembly in the bracket. The light base has a keyed plug assembly with three screw-down connection posts. The connections N, La, and Lb are labeled on the plug. La and Lb should be linked. “N” connects to terminal 3 of the relay.

The Red and Black wires of the PWM cable are attached at the solid-state relay socket terminals 4-(Black) and 5-(Red) to power the relay. Terminal 4 is also an active relay contact to connect Battery common power the light. The White wire is connected to the light’s jumpered La/Lb terminals and controls the lighting pattern of the Signal light during the match. The PWM cable then plugs into one of the four Team Light 5-pin jacks on the RC with the Black wire on the Blk pin. Any excess PWM cabling needs to be secured into a harness and anchored to the chassis.

The LED provides status indication to the field and will blink when the robot is powered up. This will verify the operation. When the OI is connected, the lights will blink twice slowly when enabled. No programming is required and the Operator cannot control the status of the light.

G.8.2 The Flag Holder

Each robot is required to have a flag holder installed on the robot to hold and display the alliance pennant color during the match. The flag holder must be mounted such that the flag is always displayed 18 (or more) inches higher than the main mass of the robot while in “Playing configuration”. The flag holder, a 12” long ½ ID” PVC (schedule 40) tube must be capped at the bottom end and be mounted in a fixed vertical position.

The red and blue bicycle flags are approximately 36” in length on a ¼” fiberglass pole.

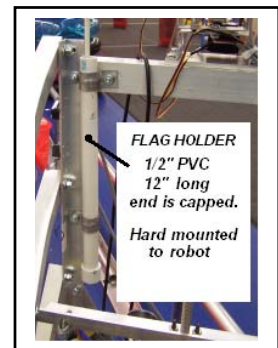

G.8.3 One Last Look

This paragraph is intended to have the team focus on the Game Rules that apply to the anticipated interactive contact in the competitions and to take a last look at their robot. The rules are very specific on the type of strategies that will not be allowed.

One area to check and address now is if your robot has by its design loose cables, hoses, cordage, netting or fabric, etc. that can be entangled or could entangle with other robots in a competition. Robots, so designed, become subject to disqualification in a match and will require repairs before continuing in the competition.

Also recall that arms or mechanisms that protrude from the robot such as forklifts, lifting arms, grapplers, etc. must not pose as a hazard for team members or event staff in that they can impale or puncture personnel or field equipment. No Wedge-type front ends allowed.

Verify that the robot has the Team Number visible in all four directions and in the letter size as specified in the Rules and that the School name and Primary sponsor’s name are also displayed prominently on the robot.

H WHERE TO BUY....

Part Description	Part Number	Product Supplier	Where to get more...
Quick-Disconnect Battery Connector	6331G1	Anderson Power Products	TBD
Analog Joysticks		AVB American Anko	http://avb.store.com/
Wheel		AndyMark, Inc	www.andymark.biz
Wheel sprocket, 24 tooth		AndyMark, Inc	www.andymark.biz
Battery Connector Safety Plug	AM-0075	AndyMark, Inc	www.andymark.biz
3D Studio Max		Autodesk	www.autodesk.com
Inventor		Autodesk	www.autodesk.com
Gearmotor & wire	MP-06364-545	Banebots.com	www.banebots.com
Motor, RS540	M1-RS540-12	Banebots.com	www.banebots.com
Transmission		Banebots.com	www.banebots.com
Bishop Wisecarver Track	TS2	Bishop Wisecarver	Email to sales@bwc.com
Steel wheel	W2	Bishop Wisecarver	Email to sales@bwc.com
Concentric bushing	B2	Bishop Wisecarver	Email to sales@bwc.com
Eccentric bushing	BX2	Bishop Wisecarver	Email to sales@bwc.com
Circuit Cellar		Circuit Cellar	www.circuitcellar.com
Accumulator	AVT-32-16	Clippard	www.clippard.com
Terminals (for keyang motor)	12015860	Delphi	www.terminalsupplyco.com
Terminal housing	12064749	Delphi	www.terminalsupplyco.com
Terminal Lugs	KPA4C	FCI Burndy	Find distributors at www.fciconnect.com (Electrical Power Inter. Div.)
Tie wraps, 8"	CT50175C2	FCI Burndy	Find distributors at www.fciconnect.com (Electrical Power Inter. Div.)
Tie wraps, 4"	CT18075C2	FCI Burndy	Find distributors at www.fciconnect.com (Electrical Power Inter. Div.)
Solenoid valve	13026684	Festo	www.festo.com
Pneumatic tubing	??-156-??	Freelin Wade	www.freelin-wade.com
Pneumatic tubing	1J-151-046	Freelin-Wade	www.freelin-wade.com
Chain		IDG	www.idglink.com
Output sprocket		IDG	www.idglink.com
Master Link for Chain		IDG	www.idglink.com
Robotics Automation Magazine		IEEE Publications	www.ieee.com/publications
Pillow block	KSTI-10	igus	www.igus.com/yesprogram/FIRST_page.asp
Flange Bearing	JFI-1012-12	igus	www.igus.com/yesprogram/FIRST_page.asp
Linear Bearing	RJI-01-10	igus	www.igus.com/yesprogram/FIRST_page.asp
Aluminum Shafting	AWI-10	igus	www.igus.com/yesprogram/FIRST_page.asp
Aluminum Shafting	AWI-06	igus	www.igus.com/yesprogram/FIRST_page.asp
Sleeve Bearing	JSI-1012-12	igus	www.igus.com/yesprogram/FIRST_page.asp
Flange Bearing	EFOI-06	igus	www.igus.com/yesprogram/FIRST_page.asp
Rod End Bearing	EBRI-10 R	igus	www.igus.com/yesprogram/FIRST_page.asp

Part Description	Part Number	Product Supplier	Where to get more...
Rod end Bearing	EBRI-06 R	igus	www.igus.com/yesprogram/FIRST_page.asp
Cable carrier	045-20-018-0	igus	www.igus.com/yesprogram/FIRST_page.asp
Mounting kit	0450-20-12	igus	www.igus.com/yesprogram/FIRST_page.asp
Thrust washer	MTI-10	igus	www.igus.com/yesprogram/FIRST_page.asp
9-Pin Cable (M/F) (Black)	CABLE-DB9-6FT-MF	Innovation First	www.ifrobotics.com
Servo	FR HS-322	Innovation First	www.ifrobotics.com
Radio Modem for Robot Controller	ROBOT-RADIO-RC	Innovation First	www.ifrobotics.com
Radio Modem for Operator Interface	ROBOT-RADIO-OI	Innovation First	www.ifrobotics.com
Relay Module (Spike)	SPIKE-RELAY-H	Innovation First	www.ifrobotics.com
Robot Controller Unit	FR-2006-RC	Innovation First	www.ifrobotics.com
Operator Interface Unit	FR-2006-OI	Innovation First	www.ifrobotics.com
Wall Adapter - OI	AC-ADAPTOR-OI	Innovation First	www.ifrobotics.com
PWM/Relay Cable	CABLE-PWM-36	Innovation First	www.ifrobotics.com
PWM/Relay Y Cable	CABLE-PWM-Y	Innovation First	www.ifrobotics.com
Speed Controller (Victor 884)	FR-VIC884	Innovation First	www.ifrobotics.com
9-Pin Cable (F/F), Tether	CABLE-DB9-6FT-FF	Innovation First	www.ifrobotics.com
Camera Module	CAMERA-CMU-2	Innovation First	www.ifrobotics.com
Transmission Support Plate, Top	KITBOT-BBMNT-TOP	Innovation First	www.ifrobotics.com
Circuit Breaker Bag	CB-20A, CB-30A, CB-40A	Innovation First	www.ifrobotics.com
Pan/Tilt Brackets	FRC-PANTILT-01	Innovation First	www.ifrobotics.com
Bumper, C-Channel	KITBOT-BUMPER	Innovation First	www.ifrobotics.com
Main Chassis Rail	KITBOT-RAIL	Innovation First	www.ifrobotics.com
End Cap	KITBOT-ENDCAP	Innovation First	www.ifrobotics.com
Transmission Support Plate, Bottom	KITBOT-BBMNT-BOT	Innovation First	www.ifrobotics.com
Chassis Stiffener	KITBOT-STIFFENER	Innovation First	www.ifrobotics.com
Hardware Kit	FRC-KITBOT-HDWR-A	Innovation First	www.ifrobotics.com
Hardware Kit	FRC-KITBOT-HDWR-B	Innovation First	www.ifrobotics.com
Transmission Angle Bracket	KITBOT-BBMNT-ANGLE	Innovation First	www.ifrobotics.com
Transmission Hardware Kit	FRC-KITBOT-BB-HDWR	Innovation First	www.ifrobotics.com
EasyC Flier		Intelitek	www.intelitek.com
Fitting	3101 04 10	Legris	Find distributors at http://www.legris.com/
Vibration Isolators	SMB003-0100-2	Lord	Find distributors at http://www.lord.com/
Machine Science Account		Machine Science	www.machinescience.org
Robot Magazine		Maplegate Media Group	www.botmag.com

Part Description	Part Number	Product Supplier	Where to get more...
2.5" CIM Motor	FR801-001	Marcus Sales	www.ifrobotics.com or http://www.banebots.com/
Bearings (3/8") - S3KDD		MBB Bearings	Email to sales@mmbbearings.com
MPLAB CBOT Compiler	C-BOT-COMPILER	Microchip	www.ifrobotics.com
Battery	ES17-12	MK Battery	email to bp401@batteriesplus.com
Secondary Regulator	101-3002-1	Monnier	www.monnier.com
Secondary Reg Bracket	13536	Monnier	www.monnier.com
Pressure Switch	SM-2B-115R/443	Nason	Email to nassales@nasonptc.com
LabVIEW Software	National Instruments	National Instruments	www.ni.com
Main Regulator, adjustable	R07-100-RNEA	Norgren	Find distributors at http://www.norgren.com/usa/
Main Regulator Mounting Kit	18-025-003	Norgren	Find distributors at http://www.norgren.com/usa/
Relief Valve	16-004-011	Norgren	Find distributors at http://www.norgren.com/usa/
Pressure Gauge	18-013-212	Norgren	Find distributors at http://www.norgren.com/usa/
Light Target pack		Ozium	www.ozium.com
Vacuum cup	FC75P.4E.07UF	PIAB Vacuum Products	Email to engineering@piab.com
Vacuum Generator	01.07.996	PIAB Vacuum Products	Email to engineering@piab.com
HDPE Panel	Plastic Supply	Plastic Supply	Email to plasticsupply@conversent.net
Air Compressor	405ADC38/12	Gardner Denver Thomas	Find distributors at http://www.rtpumps.com/
Panel signal device	855PB-B12ME555	Rockwell Automation	Find distributors at http://www.rockwellautomation.com/distributor/
Solid state relay	700-SKOC2Z25	Rockwell Automation	Find distributors at http://www.rockwellautomation.com/distributor/
Relay base	700-HN121	Rockwell Automation	Find distributors at http://www.rockwellautomation.com/distributor/
Terminal Block, red	1492-J16-RE	Rockwell Automation	Find distributors at http://www.rockwellautomation.com/distributor/
Terminal Block, black	1492-J16-BL	Rockwell Automation	Find distributors at http://www.rockwellautomation.com/distributor/
DIN rail (1/2 m)	199-DR1	Rockwell Automation	Find distributors at http://www.rockwellautomation.com/distributor/
End anchor	1492-EAHJ35	Rockwell Automation	Find distributors at http://www.rockwellautomation.com/distributor/
Center jumper	1492-CJJ12-4	Rockwell Automation	Find distributors at http://www.rockwellautomation.com/distributor/
End barrier	1492-EBJ16	Rockwell Automation	Find distributors at http://www.rockwellautomation.com/distributor/

Part Description	Part Number	Product Supplier	Where to get more...
Microswitch	V7-2817D8-408	Sager	www.sager.com
Swim ring - red		Sangin International	To be announced via email blast
Swim ring - blue		Sangin International	To be announced via email blast
Flow Control	NAS2201F-N01-07S	SMC	
Straight fitting	KQH07-34S	SMC	
90 Elbow fitting	KQ2L07-34S	SMC	
90 Elbow fitting	KQL07-35S	SMC	
Fitting, Tee-Union	KQTO7-00	SMC	
Sub Base	SY3000-27-1T	SMC	
Fitting, Straight	KQ2H03-34S	SMC	
Fitting, 90 Elbow	KQ2L03-34S	SMC	
Solenoid Valve	SY3240-6HZ-X70	SMC	
Nuts and Volts Magazine		T&L Publications	www.servomagazine.com
SERVO Magazine		T&L Publications	www.servomagazine.com
Circuit Breaker	CB3-SM-120	Terminal Supply Company	www.terminalsupplyco.com
Maxi Style Fuse Block	JEF-531D	Terminal Supply Company	www.terminalsupplyco.com
ATC Fuse Panel	15600-12-21	Terminal Supply Company	www.terminalsupplyco.com
ATC Fuse Panel	15600-06-21	Terminal Supply Company	www.terminalsupplyco.com
Ring Terminal	323986	Tyco	www.tycoelectronics.com
Ring Terminal	320619	Tyco	www.tycoelectronics.com
Ring Terminal	52042-3	Tyco	www.tycoelectronics.com
Ring Terminal	52043-2	Tyco	www.tycoelectronics.com
Ring Terminal	52264-1	Tyco	www.tycoelectronics.com
Ring Terminal	35149	Tyco	www.tycoelectronics.com
Quick Disconnect, female	2-520407-2	Tyco	www.tycoelectronics.com
Quick Disconnect, female	4-520448-2	Tyco	www.tycoelectronics.com
Quick Disconnect, female	3-520408-2	Tyco	www.tycoelectronics.com
Quick Disconnect, male	4-521098-2	Tyco	www.tycoelectronics.com
Ring Terminal	36149	Tyco	www.tycoelectronics.com
Pressure Gauge	9690242	Wika	Find distributors at http://www.wika.com/